

Brochure

The Eaton UPS and Power Management Fundamentals Handbook

March 2013



EATON

Powering Business Worldwide

Switch  N to Eaton.



MEET PROFESSOR
WATTSON -
YOUR GO-TO GUY FOR
POWER QUALITY BASICS
[YOUTUBE.COM/UPSBACKUP](https://www.youtube.com/upsbackup)

TABLE OF CONTENTS

- Introduction **4**
- Questions to consider **5**
- Top UPS design considerations **6**
- Other UPS design considerations **8**
 - How to size a UPS **9**
- UPS cost justification worksheet **10**
 - UPS form factors **11**
- Input plugs and output receptacles **12**
 - UPS startup **14**
- The difference between VA and watts **15**
- Decentralized or central UPS? **16**
- What is three-phase power? **18**
- Increase server energy efficiencies by using high-voltage power supplies and 208V UPSs **19**
 - Worldwide voltage map **20**
 - Worldwide voltages **21**
- The nine power problems **22**
 - UPS topologies **23**
- UPS battery overview **24**
- Factors affecting battery life **26**
 - UPS software overview **27**
 - Service overview **28**
- Frequently asked questions **30**
- Electric transmission distribution system **32**
 - Eaton's Blackout Tracker **34**
- Overview of 2012 national power outage data **36**
 - Case study example one **38**
 - Case study example two **40**
- Commonly used acronyms **42**
- Glossary of power terms **44**



THERE'S A LOT
TO SEE IN THIS
HANDBOOK.

Introduction



Welcome to the Eaton UPS and Power Management Fundamentals Handbook.

From plug and receptacle charts and facts about power problems to an overview of various UPS topologies and factors affecting battery life, you'll find a wealth of pertinent resources designed to help you develop the optimum solution. We have also included valuable, real-world case studies that showcase exactly how Eaton® can help you to develop the best power protection solution.

This handbook is your one-stop source for essential information ... whether you need power protection for small, medium or large data centers; health care facilities; or other environments in which ensuring uptime and safeguarding data are critical.

Why a UPS?

In general, a UPS protects IT equipment and other electrical loads from problems that plague our electrical supply, performing the following three basic functions:

1. Preventing hardware damage typically caused by surges and spikes. Many UPS models continually condition incoming power as well.
2. Preventing data loss and corruption. Without a UPS, devices that are subjected to a hard system shutdown can lose data completely or have it corrupted. In conjunction with power management software, a UPS can facilitate a graceful system shutdown.
3. Providing availability for networks and other applications while preventing downtime. In some cases, they provide enough battery runtime to ride through brief outages; in other cases, they provide hours of runtime to ride through extended power outages. UPSs are also paired with generators to provide enough time for them to power up.

Questions to consider

OUR DATA CENTER
IS A TOTAL ZOO.
GOOD TIMES.



When it comes to backup power, here are some basic questions to ask yourself.

Applications

1. How often do you refresh and maintain your IT hardware (including servers)? What about your UPS equipment?
2. If you have a converged data-voice network, have you protected all critical switches?
3. If you have virtualized your servers, have you considered the impact on your UPS equipment?
4. What would happen if the power went out at your facility right now?
5. Have you thought about the impact of damaged or corrupted data?
6. How much energy do your UPS units consume? How efficient are they?
7. What is the air speed velocity of an unladen swallow? *An African swallow.*

UPS-specific

1. What size UPS do you need? (kVA or amperage)
2. What voltage is currently available at your site?
3. What voltage do you need?
4. What runtime do you want?
5. Are there any clearances or size constraints?
6. Do you have bypass requirements?
7. What types of input and output connections are required?
8. Is there a generator on site?
9. Does the UPS need to be scalable?
10. Do you need redundancy?

Accessories

1. How is power getting from the UPS to your equipment?
2. Do you have a need for enclosures, communications, seismic mounting, floor stands or rail kits?
3. Is a maintenance bypass switch needed?

Software

1. Is there a need to have orderly scheduled shutdowns?
2. Do you want to remotely monitor the UPS?
3. Would you like to remotely notify others of UPS events?
4. How will your UPS software manage virtual servers during an extended power outage?

Service

1. Do you need immediate factory response?
2. What kind of parts and labor coverage do you need?
3. Do you want any type of preventive maintenance?
4. When's the last time you checked the batteries in your existing UPS units?

Top UPS design considerations

The following factors outline the key design considerations to take into account when analyzing your needs.

1. Power environment: single- and three-phase

Understanding your existing power infrastructure is a crucial step in the qualification and sales process. While you may focus on larger, three-phase power systems, the majority of IT managers are dealing primarily with single-phase equipment, often at the rack level.

Many existing computer rooms and small to mid-sized data centers have single-phase loads at the rack level. Ground-up designs are increasingly moving three-phase power to the point of utilization to gain efficiencies and reduce costs, creating great opportunity for three-phase solutions in new construction.

2. Installation environment

It's imperative to understand how a prospective UPS will be deployed. Since most environments support several different solutions, you may need to evaluate these options.

3. Power load

The VA or watt rating of your power loads is one of the most important factors in identifying the right UPS. After identifying the power environment (if the UPS needs to be single- or three-phase), the size of the UPS further narrows the selection. In single-phase deployments especially, it often makes sense to select a UPS that exceeds current power requirements but offers greater runtimes and allows for future growth.

4. Availability and battery runtime

This is where you need to determine your true runtime requirements. While runtime may seem like a simple thing to quantify, understanding the facts behind the numbers help contribute to the development of end-to-end solutions.

Generally, the amount of runtime required can significantly affect the solution cost, but many Eaton solutions are actually more cost-effective in extended runtime applications.

There are four basic battery runtime configurations:

1. UPS with 10 to 15 minutes of runtime and no generator. You are covered for 90 to 95 percent of power outages. You can either use UPS shutdown clients to save your data or stay online as long as possible before the system crashes.
2. UPS with 10 to 15 minutes of runtime and a generator. You have a very reliable setup and most generators will startup within one minute (five minutes maximum). You are covered for most situations.
3. Redundant UPSs, generator and two power feeds for dual-corded servers. You have a lot of money and/or are really worried about the power failing. It's time to get a consultative person on-site to help you figure it out.
4. UPS with two or more hours of battery runtime. In some cases, generators may not be practical and you must rely entirely upon batteries.

MY IT PRO SAYS EATON HELPS HIM TRIM THE FAT. FRANKLY, I'M A LITTLE WORRIED.





I LOVE MAKING PLANS.
EVIL ONES!



5. Scalability

It's always important to consider your future expansion needs when evaluating solutions. Eaton's scalable UPS solutions provide a competitive advantage by offering a cost-effective way to increase capacity. Virtually all Eaton UPSs with a 6 kVA or greater power rating offer some form of scalability, either through a simple firmware upgrade, the addition of modular hardware components or the paralleling of multiple UPSs.

For cost-conscious or budget-constrained customers, a UPS with inherent scalability often proves to be the best value in the long run, allowing you to increase capacity without purchasing additional hardware. A simple kVA upgrade is all that's needed to enable a UPS with inherent scalability to operate at full capacity.

You may want to service the UPS yourself. If that's the case, look for a unit that allows you to add capacity with power and/or battery modules.

While modular solutions—including multiple, paralleled systems—are often a more affordable option initially, they can be a more expensive solution over the long term due to added hardware and installation costs. Depending on your needs, a larger, centralized, non-modular system with inherent scalability might ultimately be the most cost-effective solution.

6. Power distribution

It is important for you to consider how power will be delivered to your critical equipment. In some cases, you may simply plug loads directly into the UPS. In others, you may need large PDUs to distribute power. You may also incorporate rack-based power strips or ePDU units into your design.

7. Manageability

While a UPS protects the attached load during a power outage, power management software is required to ensure that all work-in-progress is saved and that sensitive electronic equipment is gracefully shut down if the power outage exceeds the battery runtime of the UPS. Without software, the UPS simply runs until its batteries are depleted and then drops the load. In addition to this basic functionality of UPS software, you should consider the following monitoring and manageability capabilities:

- Power event notifications, including emails, pop-up alerts and text messages to pre-designated recipients
- Logging of power events
- Advanced capabilities in virtual environments, including integration into VMware's ESXi and vSphere and Microsoft's Hyper-V
- Dedicated battery monitoring and advanced service notifications
- Remote monitoring by service personnel from the UPS manufacturer.

8. Operation and maintenance

While you may value the ability to service your own equipment, the vast majority of IT and facility management professionals prefer the peace of mind that comes with full factory support through on-site service or an advanced UPS exchange agreement. To make an informed decision on service support, you must accurately assess your own technical and service capabilities. You should also look at the various UPS product designs to gauge how easy it is to swap out battery and power modules.

9. Budget

Although the latest performance features of a UPS may fit nicely with what you are looking for, budget constraints may force you to make trade-off decisions. Be prepared to prioritize your needs for redundancy, scalability, efficiency, software management, modularity and serviceability.

Other UPS design considerations

The following design guidelines should be reviewed and followed prior to ordering the appropriate UPS solution.

1. Check to see if there's an adequate electrical supply near the UPS.

Compare UPS fuse ratings (amps) and breaker types and whether any electrical work may be needed (i.e., cabling to the UPS terminal block input).

2. Find out the dimensions of the UPS and include any battery cabinets.

Make sure your installation site has enough space available.

3. Ensure the UPS can be placed in its final position.

Will the UPS components fit through doors? Are there any stairs? Please consult Eaton's website for detailed UPS dimensions and specifications: powerquality.eaton.com.

4. Verify that the floor is strong enough to support the UPS and battery cabinets.

The UPS and its battery cabinets can be heavy, so make sure the site has the proper floor loading capacity.

5. Confirm that the UPS will have adequate ventilation.

Eaton UPS models use internal fans to cool them. You shouldn't install the UPS in a sealed container or small, sealed room.

6. Always be sure which wall receptacle is required to plug in the UPS.

Only UPSs with power ratings up to 1500 VA plug into a standard 15-amp wall outlet. All others require a larger receptacle, which must be installed by an electrician. Things go more smoothly if you aren't waiting for this to be done after all of the equipment has arrived. Most small and rackmounted computers run on normal 120 volt, 15-amp electrical service. Some computers have power cords that require a higher voltage of 208V or 240V, in which case you'll need a 3000 VA or larger UPS.

7. Hardwired connections.

Hardwired outputs are generally useful if you want the UPS output to be distributed via electrical panels. Using an electrical distribution panel allows for flexibility with receptacles types. If there's no other UPS that fits your receptacle and power requirements, you may need to hardwire it. Hardwired UPS models typically require the use of a certified electrician to wire them to the electrical distribution panel, which could be a more costly option.

8. Installing small UPS models behind larger UPS models.

If you're installing a smaller UPS behind a larger UPS, you must consider the total potential power of the smaller UPS as well as other loads that will be powered by the larger UPS. For example, if you're plugging a 1500 VA UPS into a 10,000 VA UPS, you must consider the load of the smaller UPS rather than just the load that's plugged into it. In addition, the larger UPS must be at least five times larger than the smaller UPS. This design guideline must be followed due to charging capacity that may be required by the smaller UPS; any anomalies associated with the building power, and to avoid overheating or potential over loading of the larger UPS which may result in failure of the all UPS models in the string.

9. Using a UPS and a generator together.

A UPS provides backup power and actively conditions and regulates voltage. Similarly, an auxillary generator provides backup power, but typically takes 10-15 seconds to start up, depending on its type. For long-term backup servers and IT equipment, this isn't an optimal situation, so during that downtime the UPS kicks in. Basically, the UPS bridges the power gap between loss of power and generator coming online.

When choosing your UPS solution, it's important to keep power ratings in mind; you cannot size a generator in a 1:1 match to the UPS and expect successful results. There are two reasons for this: first, UPSs aren't 100 percent efficient and second, generators need to account for step loads. In addition, very small generators don't often provide enough kinetic energy to provide a smooth transition. As a rule of thumb, for 20 kVA and above, auxiliary generators should be sized 1.5 times the size of the output rating of the UPS in kW, while for 20 kVA and below, they should be two times larger. It's also important to note that gas-powered generators should be sized a bit larger.

10. Building codes.

Verify that the final UPS solution meets local building codes.

How to size a UPS

You have decided that you need a UPS. What's next? Well, you have to pick the right one!

Alternative #1:

Visit Eaton.com/UPSselector

Alternative #2:

Call our knowledgeable inside sales team: **800.356.5794**

Alternative #3:

Do it the old fashioned way. Completing these steps is also very useful for the first two alternatives.

- 1 List all equipment to be protected by the UPS. (Remember to include monitors, external hard drives, routers, etc.)
- 2 List the amps and volts for each device. These ratings can typically be found on the label on the back of the equipment. Multiply amps by volts to determine VoltAmps (VA). Some devices may list their power requirements in watts. To convert watts to VA, divide the watts by power factor. For servers, the power factor is often 0.9.
- 3 Multiply the VA by the number of pieces of equipment to get the VA subtotals.
- 4 Add the VA subtotals together.
- 5 Multiply the total by 1.2 to get the grand total. This step accounts for future expansion.
- 6 Use the grand total to select a UPS. When choosing a UPS, be sure that the total VA requirement of supported equipment does not exceed the VA rating of the UPS.

Alternative #4:

Eaton's UPS Tool for iPhone®, iPad® and iPod touch® helps you find the best UPS solution without being tied to your desk: www.powerquality.eaton.com/upstools



UPS sizing worksheet

1 Equipment	2 Amps	x	2 Volts	=	2 VA	x	3 Quantity	=	3 VA Subtotal
		x		=		x		=	
		x		=		x		=	
		x		=		x		=	
		x		=		x		=	
		x		=		x		=	
		x		=		x		=	
		x		=		x		=	
		x		=		x		=	
		x		=		x		=	
							4 Total		
							5	x1.2	
							6 Grand Total		

I CHAT WITH THE INSIDE SALES TEAM ALL THE TIME. THEY'RE COOL.



UPS cost justification worksheet

This worksheet helps you determine the estimated dollar savings that a UPS can deliver. Simply fill in the information to calculate the costs of one hour of downtime. Actual dollar amounts will vary from company to company, location to location, and industry to industry.

1. Number of critical loads:
Critical loads = any equipment running or supporting your applications (servers, routers, PCs, network devices, etc.)
2. Number of employees using critical loads:
3. Employees' average hourly earnings:
4. Estimated cost of lost business per hour of downtime
(\$1,000, \$5,000, \$10,000...)
5. Cost of service calls per hour:
6. Cost of recreating or salvaging data (if applicable):
7. Cost of replacing hardware (if applicable):
8. Cost of reinstalling software (if applicable):

9. Lost employee time (line 2 x 3):
10. Lost business (line 4):
11. Service (line 5):
12. Recreating or salvaging data (line 6):
13. Replaced hardware and software (line 7 + 8):

14. Estimated total cost per hour of downtime: \$

This is only one hour. Imagine if your systems were down all day!



UPS form factors

With applications spanning from desktops to large data centers, UPSs come in a variety of form factors.

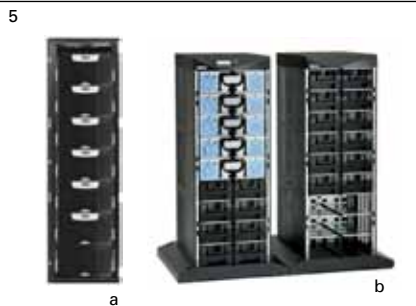

1. Desktop and tower UPS

- a. The Eaton 3S UPS also fits easily on top of or under a desk.
- b. The Eaton 9130 tower UPS fits under a desk or in a network closet.

2. Wall-mount UPS

The Eaton 5115 rackmount UPS includes hardware to mount it to a wall.

3. Rackmount UPS

The Eaton 9130 rackmount UPS occupies only 2U of rack space (fits both 2- and 4-post racks).

4. Two-in-one rackmount/tower UPS

The Eaton 5PX UPS can be mounted in a rack or installed as a tower model.

5. Scalable UPS

- a. The Eaton BladeUPS is a scalable, redundant rackmount UPS.
- b. The Eaton 9170+ is also a scalable, redundant UPS.

6. Large tower UPS

The Eaton 9390 UPS is designed to be a central backup for multiple loads, including data centers.

A SOLUTION FOR ANY SITUATION. I COULDN'T HAVE DESIGNED IT BETTER.



Input plugs and output receptacles

WHEN IT COMES TO ELECTRICAL POWER, THERE'S NO ROOM FOR MONKEY BUSINESS!



When you receive a UPS, you should be able to plug it in right away. If a UPS can't be plugged into the wall socket, or their equipment can't be plugged into it, you've got a problem.

Any UPS with a rating of 1500 VA or below can be plugged into a standard household receptacle/socket. UPS models with ratings higher than 1500 VA use input plugs that can't be plugged directly into a standard receptacle. Many higher rated UPSs (above 1500 VA) may also be hardwired directly into the electrical distribution panel at the installation location by a licensed electrician.

Many UPS models offer a fixed set of input and output receptacles. Other UPS models can be configured with a custom set of input and output connections.

For reference we've included the following chart to help you visually confirm input and output plug/receptacle options:

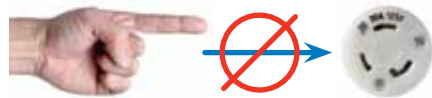

*5-15P can plug into 5-20R

R = Receptacle, P = Plug, L = Locking

For the number before the hyphen:

5 = 125V, two-pole, three-wire (grounded)

6 = 250V, two-pole, three-wire (grounded)

14 = 125/250V, three-pole, four-wire (grounded)

The number after the hyphen indicates the amperage. For example, the L5-30R is a 30A receptacle.

Input plug and output receptacle chart

5-15R 	5-15P 	5-20R 	5-20P
L5-30R 	L5-30P 	6-15R 	6-15P
L6-20R 	L6-20P 	L5-20R 	L5-20P
IEC-320-C13 (female) 	IEC-320-C14 (male) 	IEC-320-C19 (female) 	IEC-320-C20 (male)
L14-30R 	L14-30P 	IEC-309, 16A 	IEC-309, 32A
L6-30R 	L6-30P 	Terminal Block (Hardwired) 	

Know your North American receptacles

In North American markets, most facilities utilize plugs and receptacles conforming to standards established by the National Electrical Manufacturer's Association (NEMA), which uses a smart code to define what each part number represents. If you know the part number of your connector, you can find its voltage and amperage ratings. Always check with your local electrician to verify proper wiring and installation.

How big can I go?

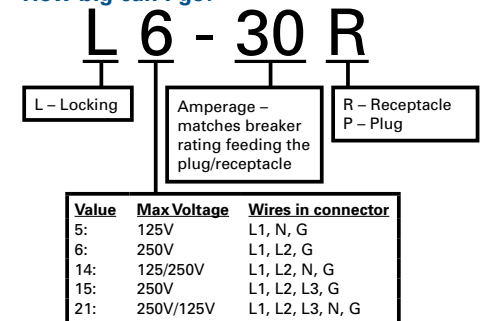

A common question from IT managers is, "I have a receptacle at my facility; what is the biggest UPS can I connect to it?" If you're looking at UPSs 6 kVA or lower, it's a pretty straight forward question to answer as shown below:

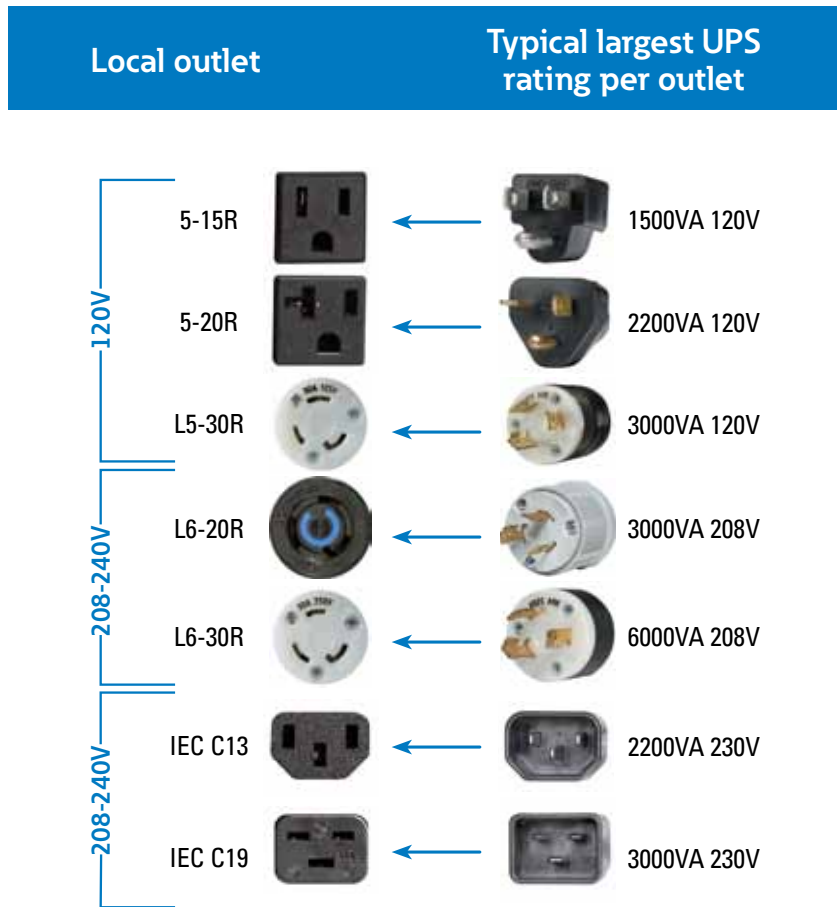

1. Fixed

Smaller UPS models like the Eaton 9130 UPS provide a fixed set of output receptacles

2. Customized

UPS models like the Eaton 9355 can be customized with a variety of output receptacles

3. Hardwired

Large UPS models like the Eaton 9390 are hardwired to incoming utility power though some models leverage output receptacles

4. Additional receptacles

Eaton ePDU products mount easily into racks and provide additional receptacles



1



2



3



4



I THINK I'LL GO WITH ASSISTED STARTUP.

UPS startup

Self-startup

UPSs equipped with a standard input plug (units 1500 VA and below) that fits into standard wall sockets are very easy to install. Units 2000 VA and above require a different wall socket that may not already exist in the location where the UPS will be installed. In these cases, an electrician can install the proper wall socket, after which you should have little problem with UPS installation.

Assisted startup

You may not feel comfortable installing electrical equipment—justifiably so. UPS installation deals with electrical power and batteries—both of which can be dangerous if not handled properly. In addition, UPS batteries can be very heavy and some units require a hardwired connection. As a result, UPS manufacturers usually offer a startup service for an additional fee. You can also hire a systems integrator, electrician or third-party service organization for UPS installation.

Manufacturer-required startup

Many three-phase UPS models (typically >40 kVA) must be started up by the UPS manufacturer to ensure they're properly installed and calibrated. In general, electricians and contractors don't have the required in-depth knowledge of the UPS. Manufacturer-trained field technicians provide an overview of the equipment and a tutorial of how to operate the UPS.



VA IS FOR WEAKLINGS.
I MEASURE MY
STRENGTH IN WATTS.



The difference between VA and watts

The engineering answer: To correctly size a UPS, it's important to understand the relationship between watts and VA. However, we must first have a brief discussion about power terminology. Real power (measured in watts) is the portion of power flow that results in the consumption of energy. The energy consumed is related to the resistance in an electrical circuit. An example of consumed energy is the filament in a light bulb.

Reactive power (measured in VAR or volt-amps reactive) is the portion of power flow due to stored energy. Stored energy is related to the presence of inductance and/or capacitance in an electrical circuit. An example of stored energy is a charged flash bulb in a camera.

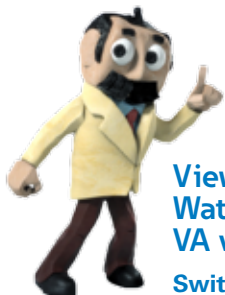

View the Professor Wattson video on VA vs Watts:

Switchon.eaton.com/ProfWattson

Apparent power (measured in VA or volt-amps) is a mathematical combination of real power and reactive power.

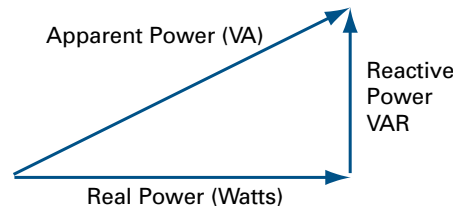

The geometric relationship between apparent power, reactive power and real power is illustrated in the power triangle below:

Mathematically, real power (watts) is related to apparent power (VA) using a numerical ratio referred to as the power factor (PF), which is expressed in decimal format and always carries a value between 0 and 1.0. For many newer types of IT equipment, such as computer servers, the typical PF is 0.9 or greater. For legacy personal computers (PCs), this value can be 0.60 – 0.75.

Using one of the following formulas, a calculation can be made to determine the missing quantity:

$$\text{Watts} = \text{VA} * \text{Power Factor} \text{ or } \text{VA} = \text{Watts} / \text{Power Factor}$$

Since many types of equipment are rated in watts, it's important to consider the PF when sizing a UPS. If you don't take PF into account, you may under size your UPS. As an example, a piece of equipment that's rated at 525 watts and has a power factor of 0.7 results in a 750 VA load.

$$750 \text{ VA} = 525 \text{ Watts} / 0.7 \text{ PF}$$

Sizing the UPS to operate at 75 percent capacity results in a UPS with a 1000 VA rating ($750 \text{ VA} / 0.75 = 1000 \text{ VA}$).

The answer for the rest of us:

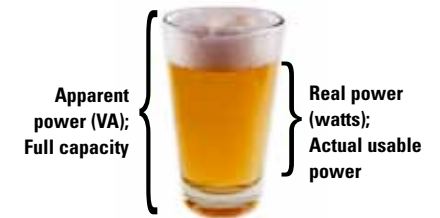

Converting amps to VA

Single phase: Multiply amps by voltage (120 volts in the U.S.). $10\text{A} \times 120\text{V} = 1200 \text{ VA}$.
Three phase: Amps x volts x 1.732 = VA.

Decentralized or central UPS?

Decentralized or central UPS?

Is a single, larger UPS better, or is it best to have multiple, smaller UPSs? Naturally, the answer is that it depends on a number of factors. In a decentralized (also known as distributed) UPS configuration (see Figure 2), multiple UPSs support a handful of devices or perhaps only a single piece of equipment. Decentralized UPSs typically use plug and play connections and are usually

less than or equal to six kVA. In a central UPS configuration (see Figure 1), a larger UPS supports multiple devices. A centralized UPS is typically hardwired into an electrical panelboard. The following tables include a number of factors to consider when making a decision between a decentralized and central UPS. In the end it's often best to simply go with the strategy that you are comfortable with.

Central UPS

Why you'd choose a central UPS solution	Why you wouldn't
Typically, the sales and service life of the UPS is longer.	A single UPS can mean single point of failure. You can overcome this concern with an N+1 or N+X UPS for redundancy.
A single UPS is easier to monitor, service and maintain than lots of smaller UPSs.	The single UPS may not be close physically to the equipment it will protect. A single electrical distribution panel may not feed all equipment.
Larger UPSs will be three-phase and/or 208V, 400V or 480V and often result in more efficient operation and lower operating costs.	There is no space for a large UPS.
A central UPS is often housed away from high traffic areas. As a result, it's less easily disrupted, accidentally damaged or maliciously interfered with.	A central UPS generally requires a trained service technician or electrician to service, maintain or install.
A central UPS can be located where cooling is more tightly controlled. Remember, heat is the enemy of the batteries inside a UPS.	A central UPS may incur higher installation and wiring costs.
Though a technician may need to replace the batteries, you only have to worry about a single UPS. A distributed UPS configuration may result in various models that require different batteries. Do you want to take the time to replace the batteries on five to 20 UPSs?	

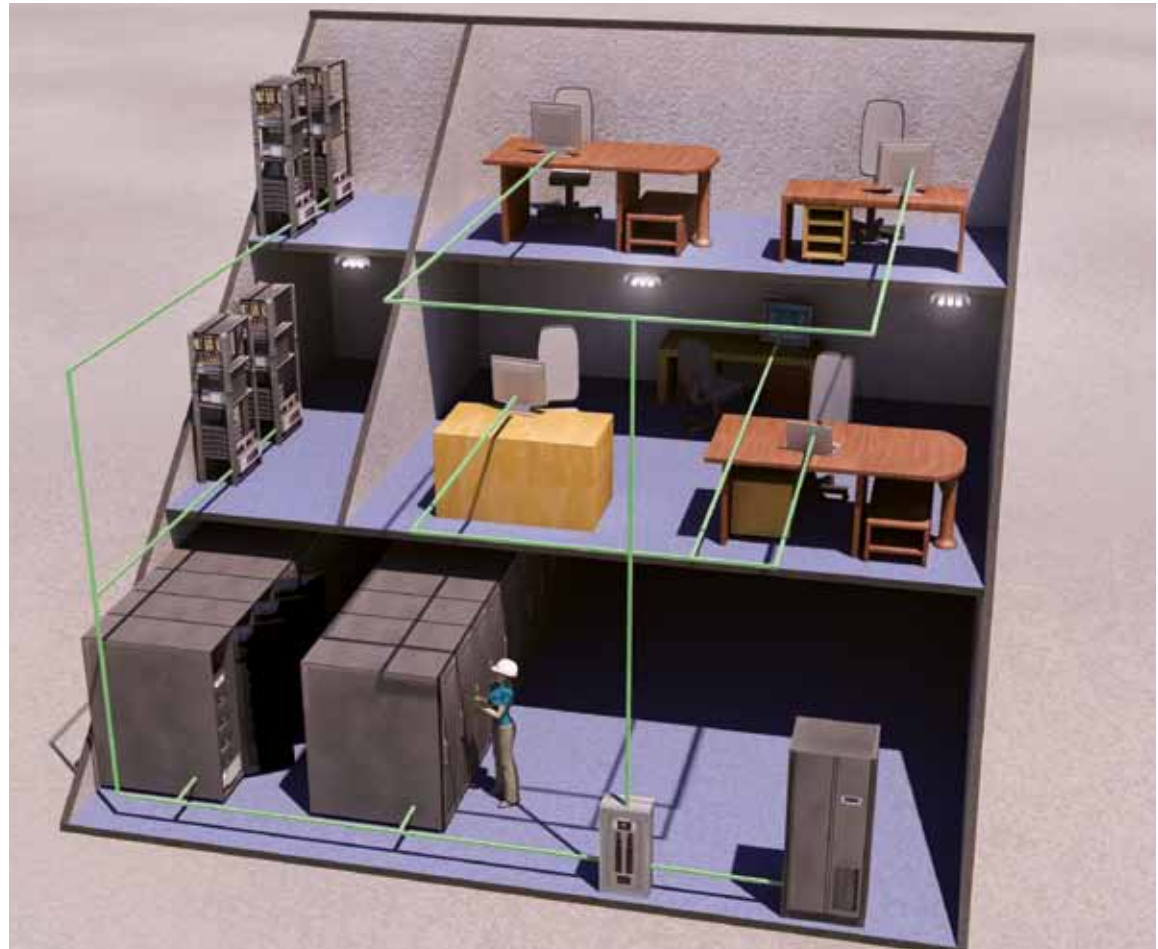

Figure 1

Combining the configurations

It's important to keep in mind that decentralized and centralized power protection deployment strategies aren't necessarily mutually exclusive. The two strategies can be used in combination to provide redundancy to mission-critical applications. For example, an entire facility may be protected by a large, centralized UPS, but a specific department such as a 24x7 call center may have decentralized UPSs as well to provide redundant protection and possibly extend runtime for call center equipment.

THAT OFFICE FURNITURE IS LOOKING REALLY OLD. I LIKE IT.



Decentralized UPS

Why you'd choose a decentralized UPS configuration	Why you wouldn't
No rewiring is required. Use existing wall sockets. Easy plug and play installation. Can also be redeployed easily if IT systems are moved.	If a generator supports the building, smaller standby and line-interactive UPSs may not be able to function while it's running.
Requires lower capital outlay and installation costs. Fits within IT manager purchase limits. Generally don't need to approve a large capital expense. Will most likely not require additional installation costs from electrician.	No central panelboard exists or there's no room for the UPS.
You have no idea how much your company will grow and don't want to get locked into a particular UPS.	You don't want to monitor or service a bunch of UPS units. A decentralized design may require more time and focus to keep up with replacing batteries and maintaining multiple UPSs.
You already have a number of smaller UPS units that are fairly new and you don't want to discard them. (Most UPS manufacturers offer a trade-in program.)	You want a single UPS that can be shut down using emergency power off. Also, a decentralized design may not offer redundancy and other capabilities provided by a larger, central UPS.
Power conditioning is implemented at the point of use, which mitigates any electrical disturbances that may be coupled into the distribution wiring of a centralized system.	Adding redundancy, extended runtime or maintenance bypass functionality to multiple UPSs can be costly.
Diverse applications within a building may require varying levels of power protection and functionality. For example, extended runtime can be configured for specific applications, eliminating the need to add additional battery modules for less critical equipment.	Multiple audible alarms/alerts may be irritating.

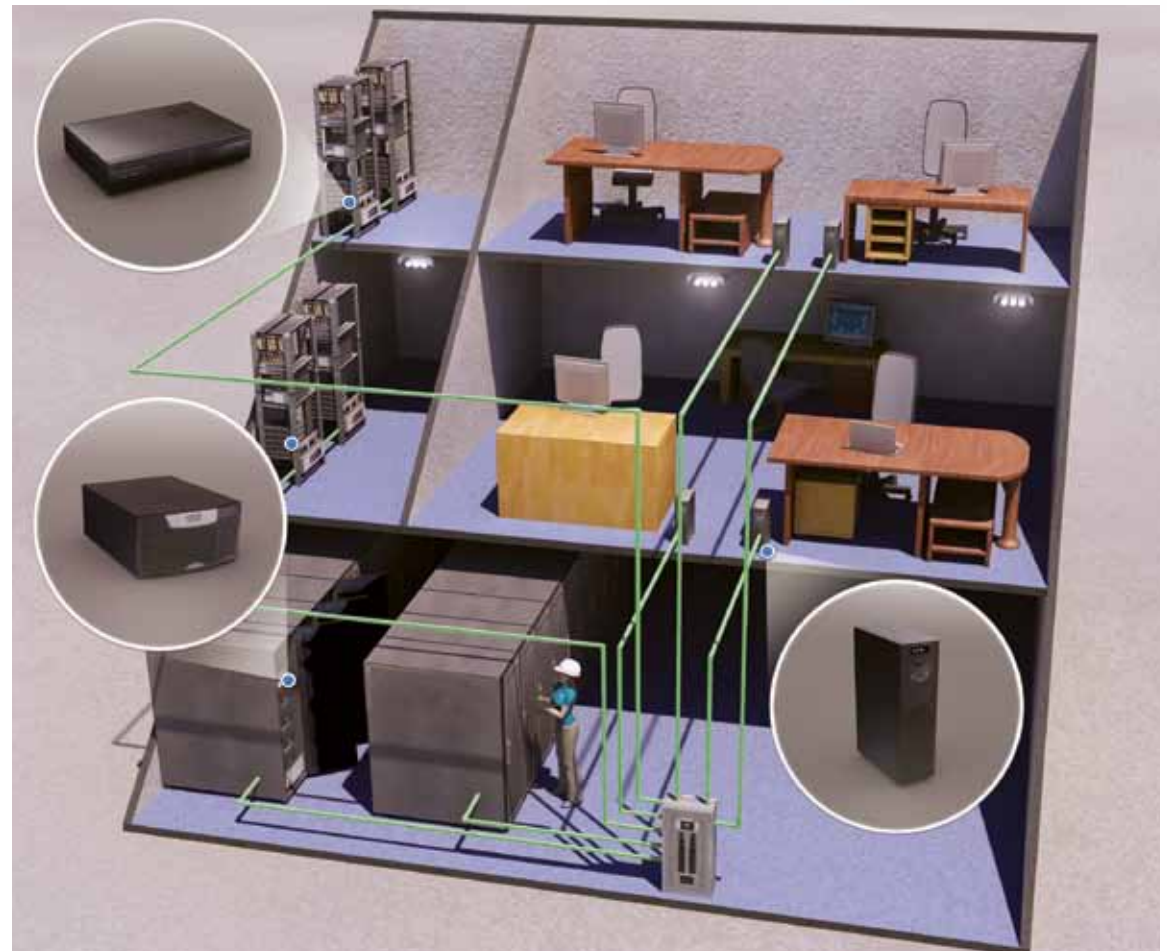

Figure 2

What is three-phase power?

Three-phase power, the most efficient way to distribute power over long distances, allows for large industrial equipment to operate more efficiently. It's characterized by three single-phase waves that are offset in their phase angle by 120 degrees, or one-third of the sine wave period as illustrated in Figure 1.

Three-phase voltage can be measured from each phase to neutral or from one phase to any other. The voltage relation between phase-to-neutral and phase-to-phase is a factor of the square root of three (e.g., 120V versus 208V).

Conversely, single-phase power is distributed through common household outlets to power everyday equipment such as laptops, lighting and televisions. When looking at an oscilloscope image of the voltage coming out of a single-phase outlet as illustrated in Figure 2, there's only a single wave. Single-phase power is obtained by simply using only one phase of a three-phase system. Its root mean square (RMS) voltage is 120V (for North America) and it oscillates between its peaks of $\pm 170V$ at 60 Hz (or 60 times a second).

Single-phase or three-phase power?

Single-phase advantages	Three-phase advantages
The standard for locations where three-phase power is unavailable.	Can help balance the loads on the utility power of the building.
Usually easier to distribute power in low kVA and low-density applications.	Usually easier to distribute power in higher kVA and high-density rack applications.
	Allows for smaller amperage electrical devices within the solution (breakers, wiring, panels, etc.).

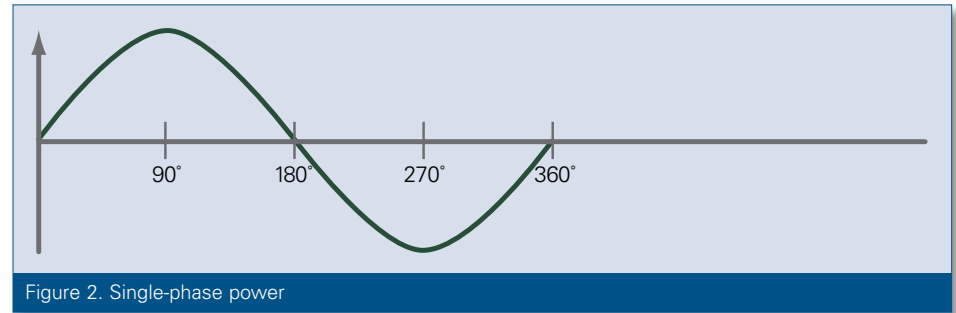
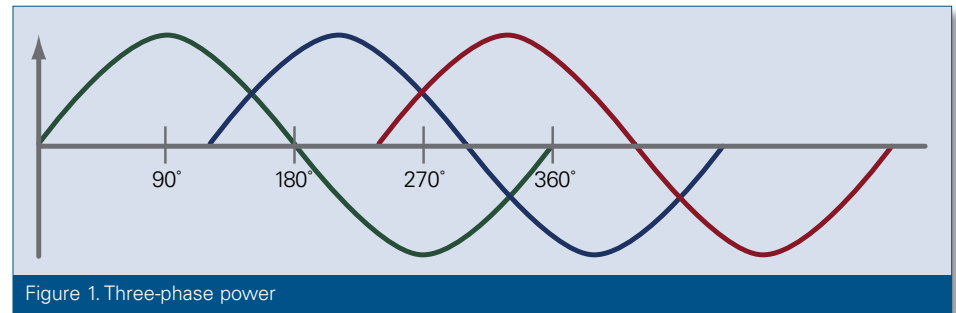

**DID SOMEONE SAY
THREE-PHASE POWER?**



Increase server energy efficiencies by using high-voltage power supplies and 208V UPSs

Maximizing energy efficiencies in today's data centers has become an important factor in saving costs and reducing an organization's carbon footprint. While there are new energy-saving tools and technologies being introduced every day, understanding existing methods and systems can bring immediate efficiencies and savings, often without an additional investment.

One such method is to operate equipment at high-line voltage and use 208V UPSs, which maximizes energy efficiency and uptime, and saves money. IT devices equipped with a C14 plug are capable of running on high voltage, which can dramatically increase efficiency.

Even small increases in UPS efficiency can quickly translate into tens of thousands of dollars in savings. For example, assuming a utility rate of 10 cents per kWh, a 60 kW N+1 redundant configuration would save more than \$30,000 over five years. High UPS efficiency also extends battery runtimes and produces cooler operating conditions, resulting in lower utility bills.

At first glance, high-voltage input power seems counter-intuitive when thinking about energy savings. However, in the real world, power supplies operate more efficiently at high voltage. The typical server switch-mode power supply has an efficiency rating between 65 and 80 percent, with some special-purpose products able to reach 90 percent efficiency. Lower voltage causes the power supply to operate at the lower end of this range.

When operating at 208 volts, a 1 to 2 percent difference in efficiency can be experienced for a 1000W power supply, depending on the load level. When the loss in the power distribution transformer (PDU) needed to get to the 120V is added, there's an additional 1.5 to 2 percent savings. Factor in cooling efficiencies and the savings can add up to between 4 and 8 percent, which translates to about \$70 per power supply. When multiplied by the number of power supplies in the server rack, the savings certainly justifies making the switch to 208 volts, especially when expanding or moving into a new location.

One of the main reasons that U.S. customers have been reluctant to switch to high voltage is that high voltage UPSs are typically fitted with IEC outlets (or even inlets) and customers don't know how to connect them to IT equipment with a traditional NEMA plug. However, all IT power supplies come with a detachable input cord with a NEMA plug on one side and an IEC plug on the other. By simply changing the standard NEMA/C13 power cord to an IEC C13/C14 power cord, these additional IT equipment efficiencies can be captured. IEC cables are fully UL-listed and are the standard method of connection in large mission-critical data centers across the U.S.

To read the complete white paper on this subject, please visit Eaton.com/pq/whitepapers.

Making the connections



Remove the standard 5-15P/C13 power cord that shipped with your IT equipment and replace it with one of the C13/C14 jumper cables that shipped with your UPS. Your IT equipment is now operating at 208V, running more efficiently and saving you money.

HIGH VOLTAGE
MAKES ME SIZZLE!



Worldwide voltage map

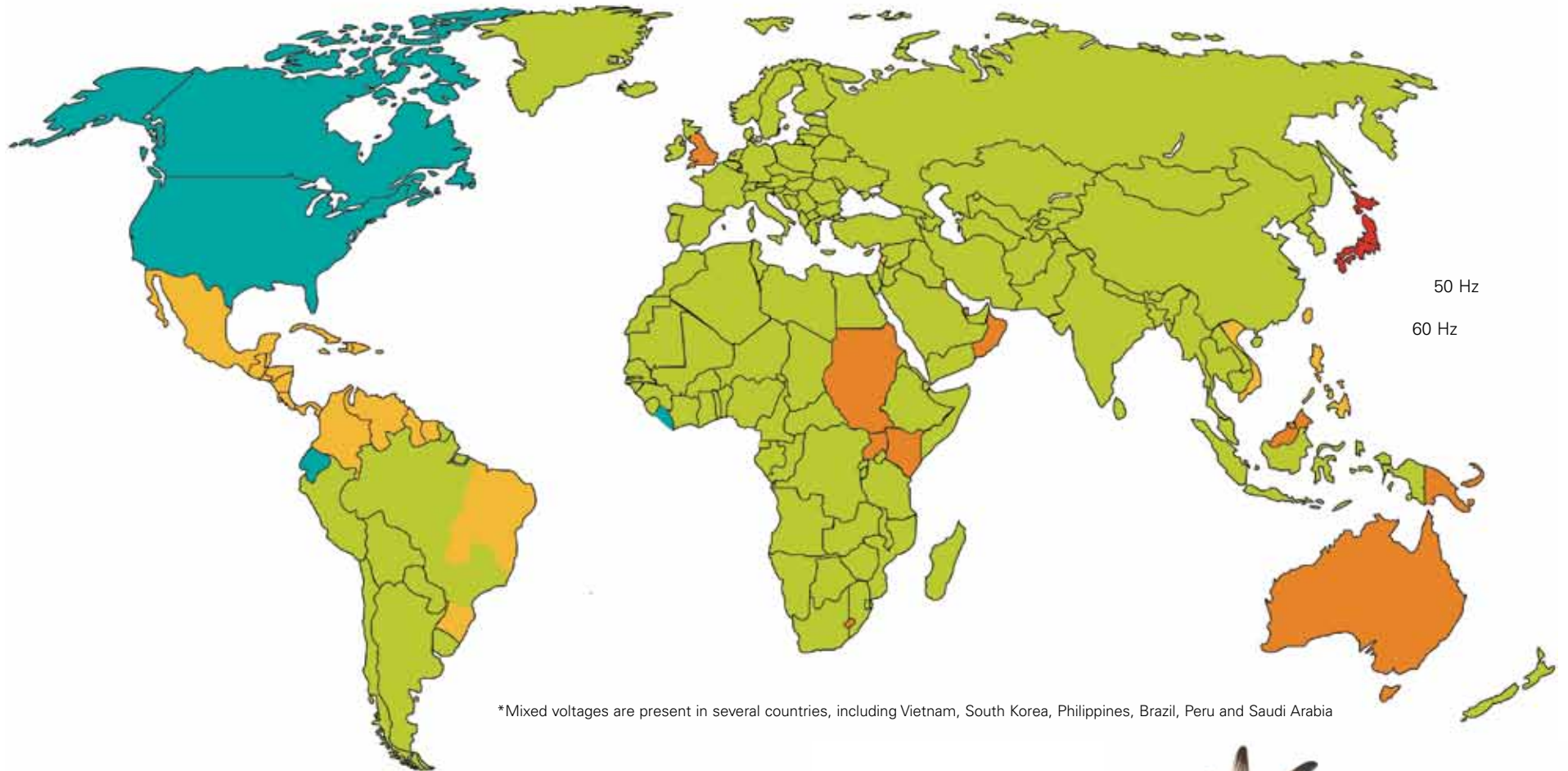

*Mixed voltages are present in several countries, including Vietnam, South Korea, Philippines, Brazil, Peru and Saudi Arabia

Single-phase voltages*

- 110-127V; 60 Hz (also 208V; 60 Hz)
- 110-127V; 60 Hz
- 100V
- 220/230V; 50 Hz
- 240V; 50 Hz

I ROAMED THE
WORLD BEFORE
THERE WERE
VOLTAGES.



The nine power problems

In an ideal world, your wall socket would provide an infinite stream of perfect power, at constant voltage and cycling exactly the same number of times per second. Don't count on it.

Power Problem	Definition
1 Power Failure	When a superhero loses his ability to fly or a total loss of utility power.
2 Power Sag	Post-lunch sleepiness or short-term low voltage.
3 Power Surge (Spike)	Rush of energy following a double shot of espresso or short-term high voltage more than 110 percent of normal.
4 Under-voltage (Brownout)	When your amp's too wimpy to handle the bass line or reduced line voltage for an extended period of a few minutes to a few days. Often happens during the summer months when everyone is cranking up their air conditioners.
5 Over-voltage	Inhuman cheerfulness exuded by aerobics instructors or increased line voltage for an extended period of a few minutes to a few days.
6 Electrical Line Noise	Excuse you use to get off the phone quickly or a high power frequency power wave caused by radio frequency interference (RFI) or electromagnetic interference (EMI).
7 Frequency Variation	Fluctuation in how often you do laundry from week to week or a loss of stability in the power supply's normal frequency of 50 or 60 Hz.
8 Switching Transient	Breaking up with your significant other only to get back together every six months or instantaneous under-voltage in the range of nanoseconds.
9 Harmonic Distortion	"Music" blaring from your nephew's headphones or the distortion of the normal power wave, generally transmitted by unequal loads.

AH, MORE
MINIONS FOR
MY EVIL PLAN!



UPS topologies

There are several different UPS topologies that provide varying degrees of protection. Selecting the best fit depends on several factors, including the level of reliability and availability desired, the type of equipment being protected and the application/environment. While all four of the most common UPS topologies outlined below meet the input voltage requirements for IT equipment, there are key differences in how the result is achieved, as well as the frequency and duration of demands on the battery.

Standby UPSs allow equipment to run off utility power until the UPS detects a problem, at which point it switches to battery power to protect against sags, surges or outages. This topology is best suited for applications requiring simple backup such as small office/home office and point-of-sale equipment.

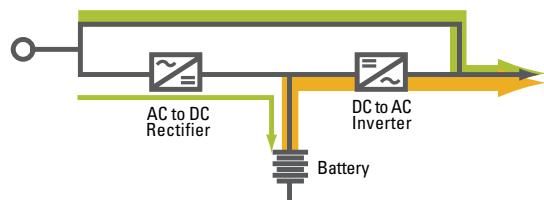

Line-interactive UPSs actively regulate voltage either by boosting or decreasing utility power as necessary before allowing it to pass to the protected equipment or by resorting to battery power. Line-interactive models are ideal for applications where protection from power anomalies is required, but the utility power is relatively clean. MDF and IDF communication closets, non-centralized server and network rooms, and general IT enclosures are ideally suited for this topology.

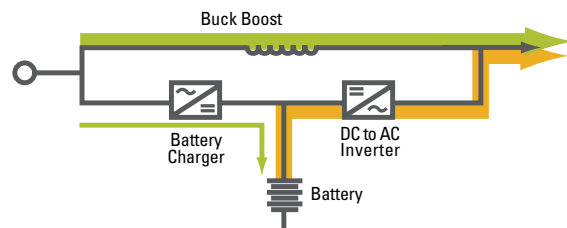

Online UPSs provide the highest level of protection by isolating equipment from raw utility power—converting power from AC to DC and back to AC. Unlike other topologies, double conversion provides zero transfer time to battery for sensitive equipment. This topology is best applied to mission-critical equipment and locations where power generally is poor.

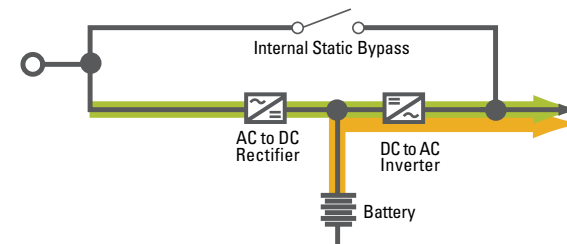

Ferroresonant UPSs operate similarly to line-interactive models with the exception that a ferroresonant transformer is used to condition the output and hold energy long enough to cover the time between switching from line power to battery power which effectively means a no-break transfer. Many ferroresonant UPSs are 82-88 percent efficient and offer excellent isolation. Although no longer the dominant type of UPS, these robust units are still used in industrial settings such as the oil and gas, petrochemical, chemical, utility and heavy industry markets.

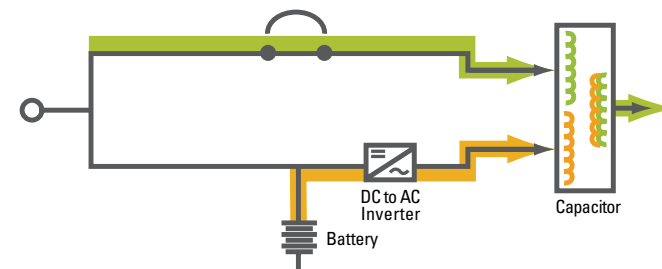

█ Normal Operation
█ Battery Power

UPS battery overview

It's well known that the battery is the most vulnerable part of a UPS. In fact, battery failure is a leading cause of load loss. Understanding how to properly maintain and manage UPS batteries can extend their service life and help prevent costly downtime.

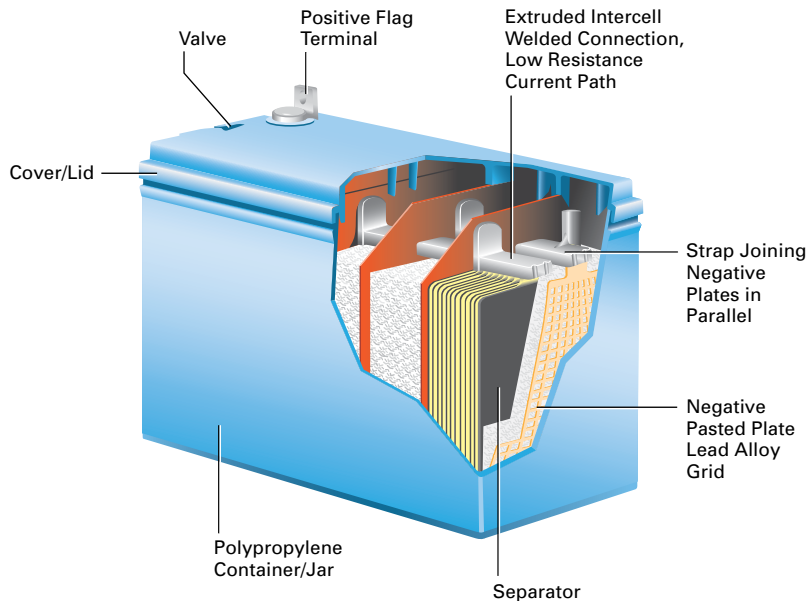

Figure 2. Internal and external components of a valve-regulated lead acid (VRLA) battery.

Valve-regulated lead acid (VRLA) batteries, also known as sealed or maintenance free are most commonly used in UPSs. VRLA batteries are sealed, usually within polypropylene plastic, which offers the advantage of not containing any sloshing liquid that might leak or drip. Because water can't be added to VRLA batteries, recombination of water is critical to their life and health, and any factor that increases the rate of evaporation or water loss—such as temperature or heat from the charging current—reduces battery life.

Frequently asked questions: batteries

1. What is the “end of useful life”?

The IEEE defines “end of useful life” for a UPS battery as the point when it can no longer supply 80 percent of its rated capacity in ampere-hours. When your battery reaches 80 percent of its rated capacity, the aging process accelerates and the battery should be replaced.

2. Is there any difference between the batteries used by smaller UPSs, from 250 VA to 3 kVA, and the ones used by larger UPSs?

While basic battery technology and the risks to battery life remain the same regardless of UPS size, there are some inherent differences between large and small applications. Smaller UPSs typically have only one VRLA battery that supports the load and needs maintenance. As systems get larger, increasing battery capacity to support the load gets more complicated. Larger systems may require multiple strings of batteries, introducing complexity to battery maintenance and support. Individual batteries must be monitored to prevent a single bad battery from taking down an entire string, and putting the load at risk. Also, as systems get larger, wet-cell batteries become much more common.



Figure 1. VRLA batteries are frequently used in UPS or other high-rate applications.

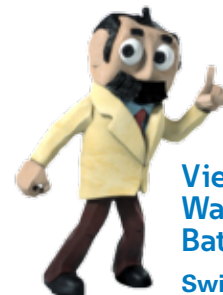

View the Professor Wattson video on Batteries:

Switchon.eaton.com/ProfWattson

3. My UPS has been in storage for over a year. Are the batteries still good?

As batteries sit unused, with no charging regimen, their life will decrease. Due to the self-discharge characteristics of lead-acid batteries, it is imperative that they be charged after every six to 10 months of storage. Otherwise, permanent loss of capacity will occur between 18 and 30 months. To prolong shelf life without charging, store batteries at 10°C (50°F) or less.

4. What is the difference between hot-swappable and user-replaceable batteries?

Hot-swappable batteries can be changed out while the UPS is running. User-replaceable batteries are usually found in smaller UPSs and require no special tools or training to replace. Batteries can be both hot-swappable and user-replaceable.



Figure 3. UPS models like the Eaton 9130 feature hot-swappable batteries for maximum uptime.

5. How is battery runtime affected if I reduce the load on the UPS?

The battery runtime will increase if the load is reduced. As a general rule, if you reduce the load by half, you triple the runtime.

6. If I add more batteries to a UPS, can I add more load?

Adding more batteries to a UPS can increase the battery runtime to support the load. However, adding more batteries to the UPS doesn't increase the UPS capacity. Be sure your UPS is adequately sized for your load and then add batteries to fit your runtime needs.



Figure 4. Adding extended battery modules increases runtime but doesn't increase the power rating or capacity of the UPS.

7. If my UPS is in storage, how often should I charge the batteries?

The batteries should be charged every three or four months to prevent loss of capacity.

8. What is the average lifespan of UPS batteries?

The standard lifespan for VRLA batteries is three to five years. However, expected life can vary greatly due to environmental conditions, number of discharge cycles, and adequate maintenance. Have a regular schedule of battery maintenance and monitoring to ensure you know when your batteries are reaching their end-of-life. The typical life of an Eaton UPS with ABM technology is 50 percent longer than with standard models.

9. Why are batteries disconnected on small, single-phase UPSs when they're shipped?

This is done to ensure they're in compliance with Department of Transportation regulations.

10. Does the UPS need to have a load on it to charge its batteries?

The UPS should have a minimum of 10 percent load to charge its batteries. Once connected to a standard supply of electricity (via input plug or hardwiring), your UPS should charge its batteries regardless of how much load, if any, is attached to it.

11. How can you be sure UPS batteries are in good condition and ensure they have maximum holdover in the event of a power failure? What preventive maintenance procedures should be done and how often?

The batteries used in the UPS and associated battery modules and cabinets are sealed, lead-acid batteries often referred to as maintenance-free. While these types of batteries are sealed and you don't need to check their fluid level, they do require some attention to assure proper operation. You should inspect the UPS a minimum of once per year by initiating a self-test.

12. How long does it take for the UPS batteries to recharge?

On average, it takes 10 times the discharge time for the UPS batteries to recover. (A 30-minute battery discharge requires about 300 minutes to recharge.) After each power outage, the recharge process begins immediately. It's important to note that the load is fully protected while the batteries are recharging, but if the batteries are needed during that time, the holdover time available will be less than it would have been if the batteries were fully charged.

13. What are the risks associated with a lack of battery maintenance?

The primary risks of improperly maintained batteries are load loss, fire, property damage and personal injury.

14. What is thermal runaway?

Thermal runaway occurs when the heat generated in a lead-acid cell exceeds its ability to dissipate it, which can lead to an explosion, especially in sealed cells. The heat generated in the cell may occur without any warning signs and may be caused by overcharging, excessive charging, internal physical damage, internal short circuit or a hot environment.

15. Why do batteries fail?

Batteries can fail for a multitude of reasons, but common reasons are:

- High or uneven temperatures
- Inaccurate float charge voltage
- Loose inter-cell links or connections
- Loss of electrolyte due to drying out or damaged case
- Lack of maintenance, aging

16. How is battery performance generally measured?

Batteries are generally rated for 100+ discharges and recharges, but many show a marked decline in charging capacity after as few as 10 discharges. The lower the charge the battery can accept, the less runtime it can deliver. Look for batteries with a high-rate design that sustains stable performance for a long service term.

Factors affecting battery life

All UPS batteries have a limited service life, regardless of how or where the UPS is deployed. While determining battery life can be tricky, there are four primary factors that contribute to a battery's overall lifespan.

1. Ambient temperature

Because the rated capacity of a battery is based on an ambient temperature of 25°C (77°F), any variation from this can affect performance and reduce battery life. For every 8.3°C (15°F) average annual temperature above 25°C (77°F), the life of the battery is reduced by 50 percent.

2. Battery chemistry

UPS batteries are electro-chemical devices whose ability to store and deliver power slowly decreases over time. Even if all guidelines for storage, maintenance and usage are followed, batteries will still require replacement after a certain period of time.

3. Cycling

After a UPS operates on battery power during a power failure, the battery is recharged for future use, which is called the discharge cycle. At installation, the battery is at 100 percent of its rated capacity, but each discharge and subsequent recharge slightly reduces its relative capacity. Once the chemistry is depleted, the cells fail and the battery must be replaced.

4. Maintenance

For larger UPS models, service and maintenance of batteries are critical to its reliability. Periodic preventive maintenance not only extends battery string life by preventing loose connections and removing corrosion, but can help identify ailing batteries before they fail. Even though sealed batteries are sometimes referred to as maintenance free, they still require scheduled service, as "maintenance free" refers only to the fact that they don't require replacement fluid.



BATTERIES ARE HEAVY. THEY GET ME PUMPED UP.

For additional information on UPS batteries, to use the Eaton battery replacement selector, or to request a free copy of Eaton's battery handbook, visit Eaton.com/upsbatteries.

UPS software overview

Operating a UPS without power management software is kind of like driving in the rain without windshield wipers—you may be protected from the downpour, but your visibility only lasts for so long.

While a UPS protects the attached load during a power outage, power management software is required to ensure that all work-in-progress is saved and sensitive electronic equipment is gracefully shut down if the power outage exceeds battery runtime. Without software, the UPS simply runs until its batteries are depleted and then drops the load.

In addition to facilitating automatic, orderly shutdown of all connected devices during an extended outage, power management software delivers a broad spectrum of other advantages. The perfect complement to any UPS solution, management software keeps a constant pulse on network health through its monitoring and management capabilities.

Most power management software is shipped with the UPS and is usually available as a free download online as well. Power event notifications are available as audible alarms, pop-up alerts on a monitor, emails to pre-designated recipients based on the condition, text messages, phone calls from our remote monitoring center, and triggers for a multitude of network and building management systems to initiate the orderly shutdown of equipment.

Some software offerings are capable of delivering a global view across the network—often from any PC with an Internet browser. Software can also provide a complete log of events and UPS utility data, which is invaluable when debugging a power anomaly. Many power management products have the ability to centralize alarms, organize data by customized views and maintain event logs for preventive maintenance of the entire installed equipment base.

The more robust and versatile software offerings are compatible with devices that support a network interface, including all manufacturers' UPSs, environmental sensors, ePDUs and other devices. Furthermore, power management software enables load segment control for UPS models supporting that feature.

Because power protection and management are just as vital for virtual machines as they are for physical servers, new software technologies have been specifically designed to provide monitoring and management capabilities in virtualized environments. Shutdown software is now compatible with VMware's ESXi and vSphere and Microsoft's Hyper-V, enabling graceful shutdown of multiple virtual machines.

To view an online demonstration of Eaton's power management software capabilities, please visit Eaton.com/intelligentpower.

EVEN I COULD USE
A LITTLE MORE
VISIBILITY TO NETWORK
POWER CONDITIONS.

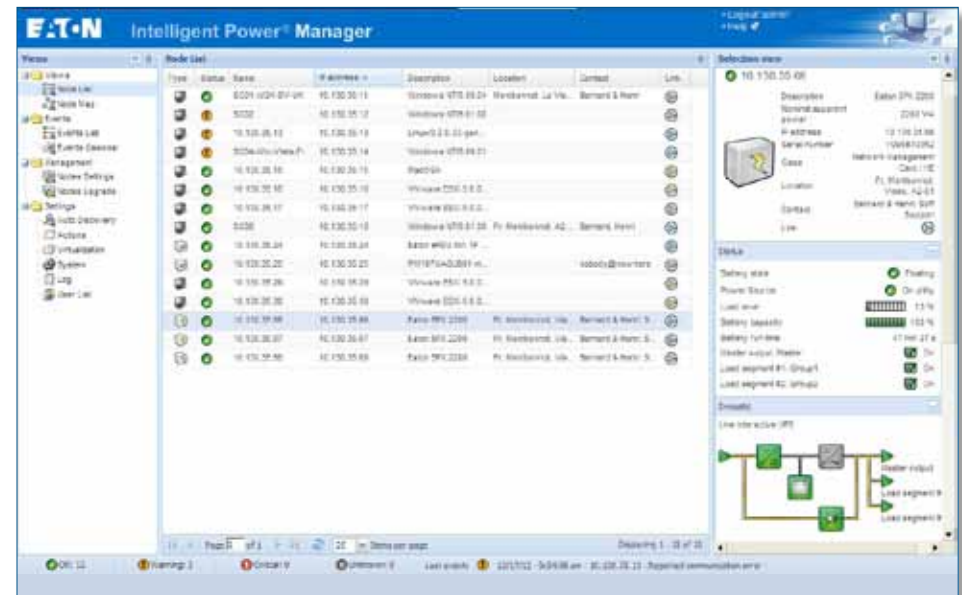

Figure 1. Eaton's Intelligent Power Manager facilitates easy and versatile remote monitoring and management of multiple devices, keeping you apprised of power and environmental conditions.



View the Professor
Watson video on
Virtualization:

Switchon.eaton.com/ProfWatson



Service overview

One of the best ways to protect your investment is by including a service plan. Scheduled preventive maintenance can help detect a wide range of ailments before they become serious and costly issues.

Research indicates that regular, routine preventive maintenance is crucial to achieve maximum equipment performance; studies show it appreciably reduces the likelihood that a UPS will succumb to downtime. The 2007 Study of Root Causes of Load Losses compiled by Eaton revealed that customers without preventive maintenance visits were almost four times more likely to experience a UPS failure than those completing the recommended biannual preventive maintenance visits.

All manufacturers' UPSs are complex devices that perform several critical power conditioning and backup supply functions and are subject to failure. Without proper maintenance, all UPSs will eventually fail over their useful life, since critical components like batteries and capacitors will wear out from normal use. A good maintenance plan delivered by trained and experienced personnel can greatly minimize this risk of failure.

I NEED MAINTENANCE, TOO!



Types of UPS service

There are several UPS service delivery methods, including:

- **Factory warranty – repair or replace.** You contact the UPS service provider and ship your UPS to a repair facility. The service provider returns the repaired unit or a refurbished unit.
- **Extended warranty – advance swap depot exchange.** You contact your UPS service provider, which ships a refurbished unit to you; the original UPS unit is returned to a repair facility. Typically this expedites a replacement UPS by the next business day and freight costs are paid both ways by Eaton.
- **Onsite repair.** You contact your UPS service provider and factory-trained field technicians travel to your site to diagnose and repair electronic or battery-related problems.

Smaller UPS products (below 1000 VA) generally can be repaired at a depot, while products over 1000 VA and up to 18 kVA can either be repaired at a depot or serviced onsite. Larger UPSs that are either hardwired (can't be unplugged) or too heavy to ship can only be serviced onsite by trained technicians.



Figure 1. Smaller UPS models are usually sent to a repair facility.

Types of service agreements

A variety of different UPS service options are available, any of which will likely save you time and money by minimizing business interruption and the costs of downtime, as well as enhancing overall return on investment by extending the lifespan of critical power equipment.

- **Support agreements, or service contracts,** usually combine parts and labor coverage (electronics, batteries or both), one or more UPS preventive maintenance inspections annually, and a combination of coverage hours and arrival response time. Plans can be tailored to meet almost any need. Special features like remote monitoring, battery replacement insurance and spare part kits may also be added.
- **Extended warranty (or basic warranty)** may also be purchased for many UPS products. A warranty commonly covers specified parts and labor such as electronic components for a fixed period of time. Warranties may have limited response times or exclude features like scheduled preventive maintenance. The more services added to a warranty, the closer it becomes to a support agreement.
- **Time and material (T&M) service** is a pay-as-you-go approach through which the service provider makes a repair only when something breaks. T&M can be done either via depot repair or onsite, depending on the UPS. This method can be an unacceptable service solution for some customers, since it's often expensive, and there's the uncertainty of not knowing when a field technician will arrive. Because support agreement (contract) customers always take priority, T&M response times can be up to five days, based on the product and location.



Figure 3. Eaton is one of the UPS companies that provides remote monitoring services.

The Eaton service offering

Eaton offers power quality services for its UPS products as well as for related equipment such as power distribution units (PDUs) and batteries. Eaton also services products from legacy brands, including Powerware, Exide Electronics, Best Power, MGE Office Protection Systems, IPM, Deltec and Lortec. Eaton has more than 40 years of experience designing and servicing industry-leading UPSs for government, healthcare, industrial and data center applications.

For more information on UPS service, and to access service-related white papers, please visit Eaton.com/upsservices.

Frequently asked questions

We compiled the following set of questions based on our extensive experience dealing with resellers and end users. For frequently asked questions about UPS batteries, please visit the UPS battery overview section on page 24.

1. What's the difference between a surge protector and a UPS?

A surge protector provides just that—surge protection. In addition to surge protection, a UPS continually regulates incoming voltage and provides battery backup in the event of a power failure. You'll often see surge protectors plugged into a UPS for added surge protection and additional output receptacles.

2. How much capacity of a UPS should I use?

To allow for future expansion, we recommend that you install a UPS at approximately 75 percent capacity. In addition, the batteries degrade over time; by oversizing, you provide room for error. In the online Eaton UPS sizing tool (Eaton.com/UPSselector) we've included a "capacity used" column.

3. How much UPS battery runtime do I need?

During an outage, you need enough battery runtime to gracefully shut down systems or switch to backup generators. You may add an optional external battery module (EBM) to increase runtime.

4. How is battery runtime impacted if I reduce the load on the UPS?

There can be a significant increase in runtime. Generally speaking, a UPS that provides five minutes at full load will provide 15 minutes at half load.

5. My business is too small for protective measures. Do I really need a UPS?

Power problems are equal-opportunity threats. Your PCs, servers and network are just as critical to your business as a data center is to a large enterprise. Downtime is costly in terms of hardware and potential loss of goodwill, reputation and sales. Also add in the delays that inevitably occur when rebooting locked-up equipment, restoring damaged files and re-running processes that were interrupted. A sound power protection strategy is cost-effective insurance.

6. Why is power quality such a problem today?

Today's high-tech IT equipment and control units are much more sensitive to electrical disturbances and are more important to the critical functions of many businesses than in the past. As a result, power quality problems today are more frequent and more costly than ever.

7. Are power quality problems always noticeable?

No. In many cases, disturbances can cause imperceptible damage to circuits and other components, a major cause of premature equipment failure and problems like computer lockups. Many power quality problems go unresolved, resulting in lost revenue and data.

8. How is reliability measured?

Power reliability is usually stated as a percent of time the power is available. For example, the power grid system in the U.S. provides three nines of reliability—the power is available for 99.9 percent of the time. Because those 8.8 hours of downtime translate into significant downtime and expense, IT and telephone network services require at least five nines of reliability.

Reliability average	Non-availability per year
99%	88 hours
99.9%	8.8 hours
99.99%	53 minutes
99.999%	5.3 minutes
99.9999%	32 seconds
99.99999%+	3.2 seconds

9. How are phone systems and IT equipment affected by inconsistent power?

Fluctuating power is a waste of valuable time and money. If customers expose their telephone systems (and any other electronic equipment) to inconsistent utility power, they're vulnerable to hardware and software damage, data corruption and communication breakdown. The time and cost of replacing equipment, as well as the business lost during breakdown and replacement, can greatly affect a company's bottom line.

10. We have a generator. Do I still need a UPS?

A generator will NOT protect your equipment against power problems. You need a UPS to guarantee that the equipment stays up until the generator kicks on and stabilizes—which often requires several minutes.

11. How much UPS capacity do I need?

Determine the total load (in watts) of the equipment you want to protect. Add 10–20 percent for future growth and decide the minimum amount of runtime you need. Use the online sizer at (powerquality.eaton.com) to identify the right solution for your application.

12. What are the different levels of surge protection?

There are three typical levels:

A. Lightning arrestors. Big and mean, usually found in large facilities located in high-risk areas. Takes an extremely high voltage and clamps it down.

B. Surge Protective Devices (SPD or TVSS). Mounted on your panelboard or load center; sometimes larger UPS models may have some level of this, but typically not a great amount. Clamps voltage down two even lower tolerances (~1 kV or less).

C. Local outlet level surge protector. A simple surge strip; small plug-and-play UPSs often have this as well. Brings voltage down to levels that will not permanently damage connected equipment (typically ~380V).

Lightning strikes have such an incredible amount of energy that only an expensive lightning arrestor would protect you from a direct hit and they often don't guarantee complete protection. For the best protection against lightning strikes, you want to develop a two-stage defense with something at your panel and something at the outlet level. Visit Eaton.com/spd for some informative videos and additional information.

13. What happens if the UPS is overloaded, for example, if the protected equipment and/or load draws more current than it can provide.

The UPS transfers the load to bypass (for a few minutes) until the overload condition is reversed. If the overload condition continues, some UPS models automatically shut down. Some models can run at 110V indefinitely in bypass.

14. What causes a UPS to be overloaded?

There are two possible answers: (1) the UPS was undersized (e.g., the load is rated at 1200 VA, but a 1000 VA UPS was provided), or (2) you plugged more equipment into the UPS than it was designed to handle.

15. I have a 3000 VA UPS. Can I just plug the unit into a standard 15A wall outlet?

Only UPSs with power ratings up to 1500 VA plug into a standard 15A wall outlet. All others require a larger receptacle, which must be installed by an electrician.

16. Why is power management software important?

Although UPSs are typically rugged and reliable, they do require ongoing monitoring and support. Power management software continuously monitors and diagnoses the state of the grid, batteries and power sources, together with the condition of the UPS's internal electronics. Eaton UPS software and connectivity cards enable remote monitoring and management capability, including graceful shutdown and load segment control.

17. Will my current UPS software monitor my new Eaton UPS?

Yes, you can monitor your Eaton UPS with any UPS or facility management software that supports the industry standard Management Information Base (MIB, RFC 1628) as long as you install the optional connectivity card. Most UPS vendors support this MIB and all good facility management software, including OpenManage, OpenView and Tivoli also support it. Extended Eaton Advanced MIBs are available for greater levels of detail.

You can remotely control your Eaton UPS using the Eaton UPS management software or through a secure web interface if you choose the optional connectivity card, which also allows for automated email alerts for power events without needing to install any software.

18. My data center only went down for a couple of minutes. What's the big deal?

When a data center goes down and then back up during a power outage without a managed shut down, it doesn't come up nicely. Storage arrays initialize after servers that try to mount their shares, while some servers boot without access to DNS servers that are also booting and thus have other problems. Although the outage was short, it can take hours to get everything back online. In addition, data corruption is a serious concern.

19. Where can I get technical help?

Contact your territory representative or call the Eaton UPS hotline at 1-800-356-5794 for pre-sales support and 1-800-356-5737 for technical support. You can also visit www.powerquality.eaton.com.

**A GENERATOR?
I ALREADY HAVE
MY OWN!**





Electric transmission distribution system

The flow of electricity begins at the utility company, where it's created at the generating station. A generator transformer at the station switchyard then steps up the voltage to minimize cable size and electrical losses.

The transmission substation then increases the voltage, which depends on the distance the power needs to travel and the amount desired. Electricity then enters the transmission system, traveling at nearly the speed of light, over heavy cables strung between tall towers. A step-down transformer located at a substation near the final destination reduces the voltage to between 22,000 and 69,000 volts, so the electricity can be carried on smaller distribution lines that carry it to the end user. Transformers that adjust the voltages down to the proper level for use are located at or near each end user facility. For commercial use, the load can range from 416 volts to 480 volts, while residential use is typically 208/120 volts in the U.S. and Canada.

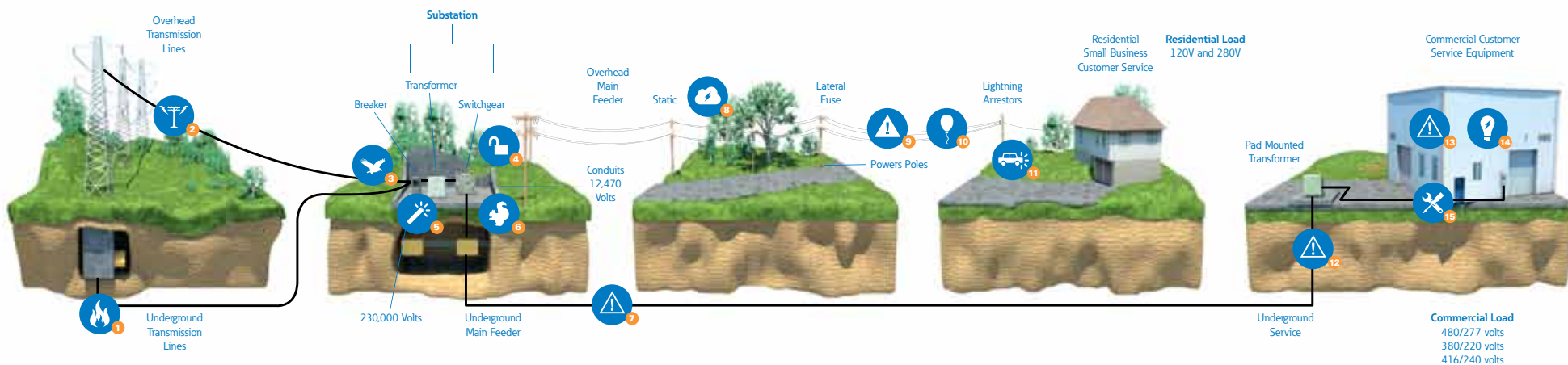

Threats to the system

At each stage, there are a number of threats that can interrupt the flow and distribution of electricity. Everything from lightning strikes to failed equipment can severely affect the end user and disrupt important and vital processes.

- 1 Fire sparked by weak wire burns through line
- 2 Lightning strike damages transmission line
- 3 Bird flies in causing short circuit
- 4 Thieves steal copper
- 5 Blown fuse at substation transformer
- 6 Squirrels and raccoons chew through a wire or wander into the wrong area
- 7 Underground explosion causes cable failure
- 8 Storm blows branches and limbs down that crash into power lines
- 9 Equipment malfunction
- 10 Mylar balloons drift into power lines
- 11 Three-car collision strikes utility pole
- 12 Failure of underground cable
- 13 Equipment failure
- 14 The power goes out and no one knows why
- 15 Utilities conduct a planned outage for repairs or upgrades

TREES, ROADS, GRASS AND POWER LINES. WHERE AM I SUPPOSED TO LAND?



Eaton's Blackout Tracker



8/20/2008 Santa Rosa, CA

Duration: 12 hour
People Affected: 1,600 people
Cause: Bad underground cable

If there are too many appliances or lights on in an area, the immediate heavy drain can cause the power to go out again in an area.

Power through

Blackout Tracker

Blackouts by: People affected Duration

Number of people affected in:
California

Sort by: [most recent](#) | [cause](#)

0k 39 2K 60K

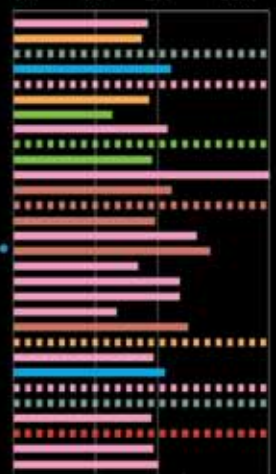

previous next

Cause Key





Show me: Nevada California Arizona

9/10/2008 Irvine, CA

Duration: 2 hours, 30 minutes
People Affected: 2,900 people
Cause: A squirrel was electrocuted and caused the outage

California Ground Squirrels live in burrows which they excavate themselves. Although they readily become tame in areas used by humans and quickly learn to take food left or offered by picnickers, they spend most of their time within 25m of their burrow and rarely go further than 50m from it. (Source: Wikipedia)

- [Submit your own power outage report](#)
- [Request a Blackout Tracker annual report](#)
- [Suggestions? Help us improve the tracker](#)

9/9/2008 Paso Robles, CA

Duration: 9 hours
People Affected: 898 people
Cause: Vehicle launched into the air and struck a power pole

9/9/2008 Camarillo, CA

Duration: 17 hours
People Affected: 98 people
Cause: Tree roots grew into an underground cable

A second outage was caused when a switch went out in the same area after the demand for electricity increased.

Eaton's Blackout Tracker monitors power outages across the U.S. and Canada to provide a snapshot of reported power outages. The Blackout Tracker is an interactive and educational way to share information about the causes, frequencies and impact of power outages. You can view a region or individual state or province to see specific information about power outages, including their cause, duration and number of people affected. Visit Eaton.com/blackouttracker to see this interactive tool and order the latest Blackout Tracker annual report.

Impact of power outages

Every day, an interruption to electrical service in homes, businesses and public sector organizations occurs, and the losses from these power outages can be extensive and of great consequence. For a business, the recovery time is significant and the costs are high. According to Price Waterhouse research, after a power outage disrupts IT systems:

- >33 percent of companies take more than a day to recover
- 10 percent of companies take more than a week
- It can take up to 48 hours to reconfigure a network
- It can take days or weeks to re-enter lost data
- 90 percent of companies that experience a computer disaster and don't have a survival plan go out of business within 18 months

Power outages can cause substantial losses for the companies affected. According to the U.S. Department of Energy, when a power failure disrupts IT systems:

- 33 percent of companies lose \$20,000-\$500,000
- 20 percent lose \$500,000 to \$2 million
- 15 percent lose more than \$2 million

ON THE WALKING DEAD, THERE IS NO ELECTRICITY. I LIKE THAT.



Overview of 2012 US national power outage data

The following data was compiled by Eaton based on reported power outages during 2012.

Total number of people affected by outages	23,488,028
(This is the sum of the number of people affected by reported power outages in the U.S. for 2012.)	
Total duration of outages	74,598 minutes (approximately 1,243 hours or 52 days)
(This is the sum of the durations of the reported power outages.)	
Total number of outages	2,808
(This is the sum of the number of reported power outages.)	
Average number of people affected per outage	12,648
(This number is determined by dividing the "Total number of people affected by outages" by the number of outages that reported the number of people affected. Not all reports of outages included number of people affected.) <i>See Note A below.</i>	
Average duration of outage	154 minutes (over 2.5 hours)
(This number is determined by dividing the "Total duration of outages" by the number of outages that reported durations. Not all reports of outages included the duration.) <i>See Note B below.</i>	

Notes:

- A. Total number of people affected (and average) is based on 2,167 (63%) of the total reported outages. Total duration of outages (and average) is based on 991 (29%) of the total reported outages. These are the number of outages that had reports including data for number of people affected and duration, respectively.
- B. Reports from news services, newspapers, websites, etc. used as sources, sometimes give statistics using different terms. For example, some reports may be based on "people" while others may be based on "addresses," "homes and businesses" or "utility customers." For purposes of this report, all of these are assumed to be and counted as people.

Reported power outages by cause in 2012

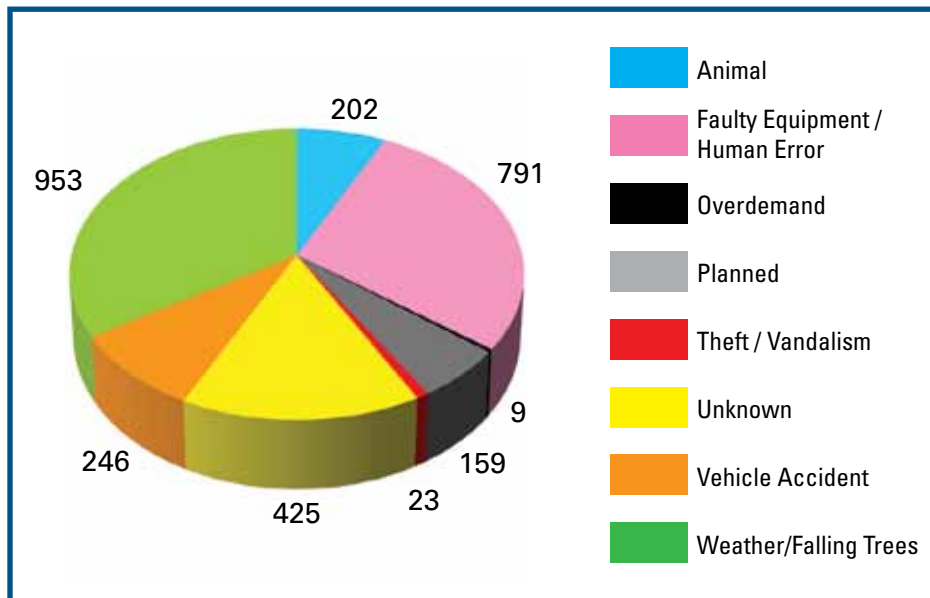

Note: Each power outage was grouped into one of seven possible causes. The outages by cause were totaled and the results displayed in the chart above. The number adjacent to the pie piece is the number of outages attributable to that cause.

Reported power outages by month/year

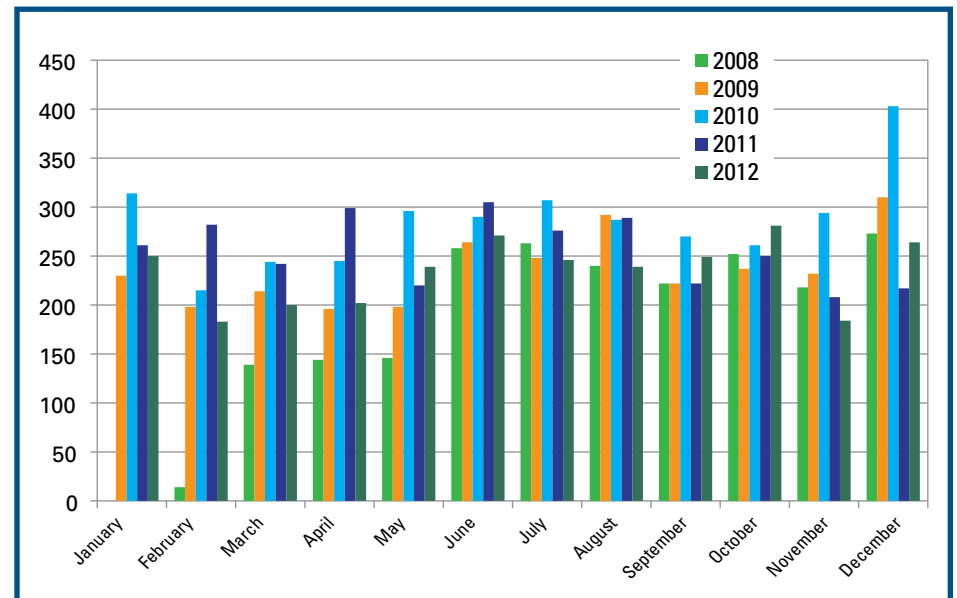

Note: Data collection began February 16, 2008.

THEY HAVE A CATEGORY FOR ANIMALS? THAT'S HARSH.



Case study example one

Challenge:

A small college with multiple satellite campuses is consolidating data centers to a brand new facility. This site is a small community branch with only single-phase loads left in the data center and it supports only small processes and equipment. It does have generator backup, which works for long-term outages, but the IT manager wants 15 minutes of runtime. Although the shutdown process takes six to seven minutes, the IT manager prefers to have 15 minutes for peace of mind. The main IT support and servers will be handled from the main campus, but some of the backup and support processes will be run from this data center and need power protection.

There's no need for scalability, as the load at the various branches will most likely decrease over the next several years. With the move to the central data center, the expectation is that over the next five years almost all the IT equipment will be housed at the main campus.

The IT manager provides a list of equipment that shows the majority of the load needing protection is telecom equipment. There are three 120V telephony racks with an average power draw of 1.5 kW each. There are two 208V racks of servers to handle the support processes that average 2.5 kW each.

Operation and maintenance: With the move to the main data center, the support staff onsite will be minimal. The IT manager wants a comprehensive support plan to handle all service and maintenance.

Budget: The budget is a major consideration, since the satellite campus IT budgets have been reduced due to IT equipment consolidation. The IT manager expects to spend less than \$20,000.

Management: The IT manager wants to continue to manage the equipment over the network but only minimal monitoring is needed.

Power distribution: The facility has several rackmount UPSs being fed from an upstream distribution panel. There's a mixture of 5-20R and L6-30R receptacles available on this distribution panel. The IT manager prefers to continue using the existing distribution panel without bringing in an electrician to rewire the facility. Eaton 9130 UPSs are available with these options in both tower and rackmount models. The IT manager can separate racks based on 208V or 120V, due to the limited equipment and ample rack space from the consolidation.

Eaton's complete solution:

Customer equipment

- 1 Onsite generator
- 2 Distribution panel
- 3 Single-phase power
- 4 Three telephony racks with a total load of 4.5 kW (120V)
- 5 Two server racks with a total load of 5 kW (208V)

Eaton equipment

- 1 Three Eaton 9130 UPSs and three EBMs provide 1.8 kW of power each and 40 minutes of battery runtime
UPS part number: PW9130L2000R-XL2U
EBM part number: PW9130N3000R-EBM2U
- 2 Two Eaton 9130 UPSs and two EBMs provide 2.7 kW of power each and 20 minutes of battery runtime
UPS part number: PW9130G3000R-XL2U
EBM part number: PW9130N3000R-EBM2U
- 3 Six ePDU models, two in each rack for the A and B feeds. Model ePBZ97 with (24) 5-20R output receptacles
- 4 Four ePDU models, two in each rack for the A and B feeds. Model ePBZ92 with (20) C13 and (4) C19 output receptacles

- 5 Intelligent Power Software Suite (free with UPS) for comprehensive monitoring and shutdown capabilities
- 6 Recommended service contract: Flex Onsite
 - Comprehensive coverage of UPS and batteries
 - Telephone technical support
 - eNotify Remote Monitoring
 - Connectivity support
 - Expedited delivery of replacement parts, modules and batteries
 - Onsite startup
 - Onsite corrective maintenance
 - Next-day 24-hour response



Case study example two

Challenge:

A data center has 480 Vac three-phase service with dual-mains, feeding an older 300 kVA UPS. There are two wall-mounted panels being fed from the two utility sources that feed the UPS (rectifier and bypass input), which is feeding a switchboard. The switchboard feeds two 150 kVA power distribution units (PDUs). It's a three-phase environment for the main UPS and single-phase UPSs within the racks.

The switchboard, fed by the UPS, is feeding two 150 kVA PDUs; the PDUs are feeding six rows of racks via cabling under the 12-foot raised floor. Each rack has metered ePDU units for in-rack power distribution, which are being fed from the PDU distribution breakers and receptacle junction boxes under the floor. With metered ePDUs in each rack, this is a nice power distribution scheme. The ePDUs are being fed through receptacle boxes under the floor with L6-30P input plugs for each rack. The IT manager also says he has a mixture of C13 and C19 outputs on each ePDU.

One or more UPSs will replace the existing 300 kVA system and be installed in the dedicated facility or power room behind the wall. In total, the facility has 54 racks of IT equipment (~1500 square feet) with a total load of 214 kW, or 4 kW per rack.

The facility has a backup generator, that suffices for long-term outages. Because he has critical phone switches and other telecom equipment, the IT manager wants 10 minutes of runtime to be safe, should he face generator problems. Since he also has two 150 kVA PDUs, the IT manager is interested in the possibility of providing two parallel UPSs for N+1 redundancy. With two UPSs providing a total of 300 kVA or more, only half the data center would be impacted in a UPS or mains failure.

With regard to service, the IT manager defers to the facility manager, who prefers complete factory support. With the systems backing up their critical data center, they want to ensure each UPS is under a service contract with ongoing preventive maintenance.

Eaton's complete solution:

Customer equipment

- 1 480 Vac three-phase service with dual-mains
- 2 Switchboard
- 3 Pair of 150 kVA PDUs
- 4 54 racks of IT equipment (~1500 square feet)
- 5 Backup generator

Eaton equipment

- 1 Two Eaton 9390 UPS (160 kVA each) providing 320 kVA of support or 288 kW (34 percent extra capacity); includes parallel configuration, Web card, side-car tie cabinet and three-breaker MBS (TD1622231129010)
- 2 Two external battery cabinets (432 Vdc) providing 12 minutes of runtime (TL1602E28211100)
- 3 54 monitored ePDU units with L6-30P input, (24) C13s and (4) C19s (PW105MIOU096)

- 4 Startup and one year of on-site service included with all 9390 units.

Recommended PowerTrust service plan:

- Parts and labor for electronics
 - 24x7 onsite corrective maintenance
 - 8-hour field technician response time
 - 8x5 preventive maintenance (1 per year)
 - Battery preventive maintenance (1 per year)
 - eNotify Remote Monitoring service
 - Discounted spare parts and upgrade kits
- 5 Intelligent Power Software Suite UPS software (free with UPS) for comprehensive monitoring and shutdown capabilities
 - 6 Future LAN drop to UPS for communications and PowerXpert for advanced monitoring and management capabilities

EATON GAVE OUR
DATA CENTER
NEW LIFE. WHAT
ABOUT ME?



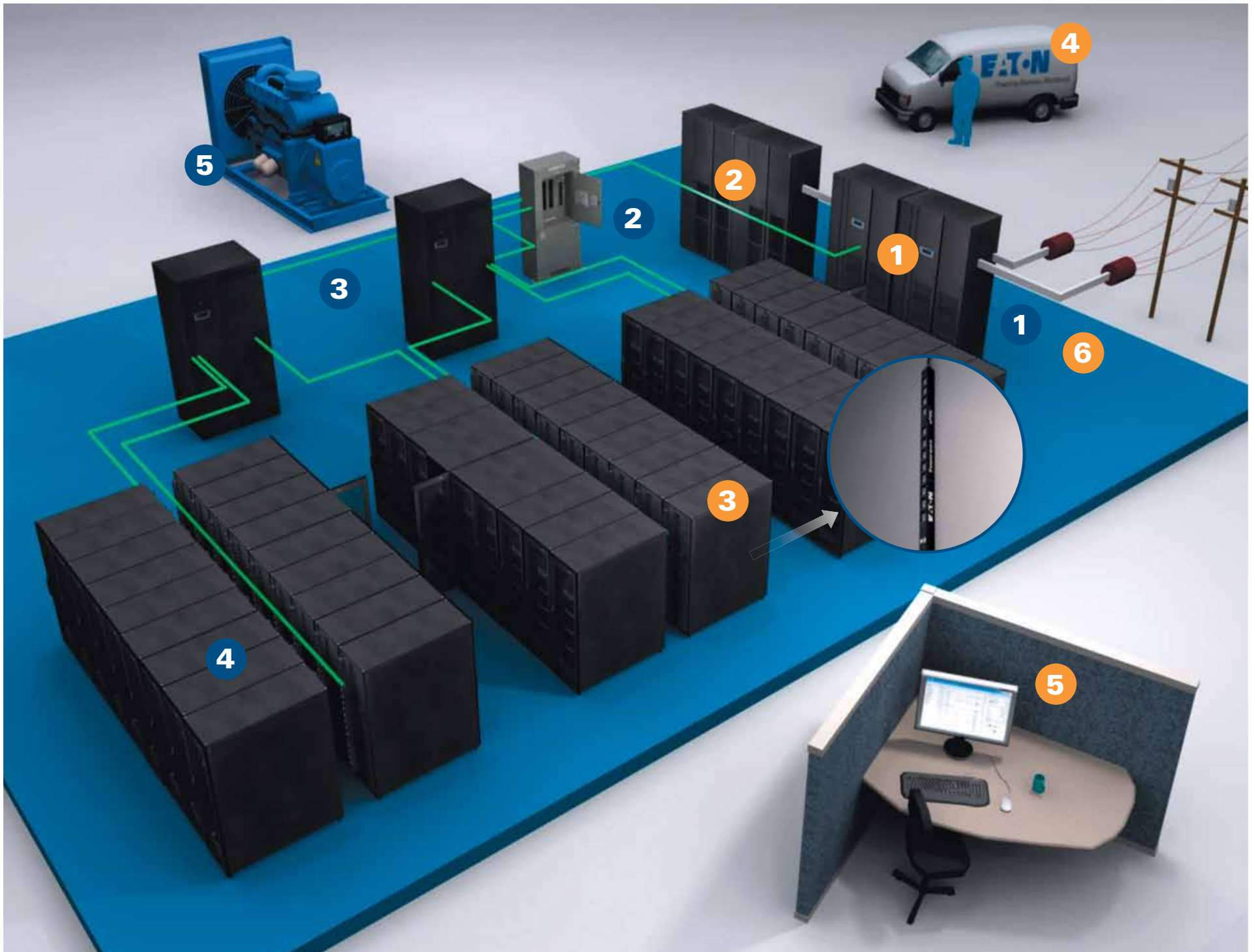

Commonly used acronyms

UPS and electrical acronyms

A	Ampere	HVAC	Heating, Ventilating and Air Conditioning	PDU	Power Distribution Unit
AC	Alternating Current	HW	Hardwired	PE	Protective Earth (also Physical Education)
AFCI	Arc Fault Circuit Interrupter	Hz	Hertz	PF	Power Factor
AH	Ampere Hour	IEC	International Electrotechnical Commission (IEC)	PFC	Power Factor Correction
ANSI	American National Standards Institute	IEEE	Institute of Electrical And Electronics Engineers	PoE	Power over Ethernet
ASCII	American Standard Code for Information Interchange	IGBT	Insulated Gate Bi-polar Transistor	PPDM	PowerPass Distribution Module
AVR	Automatic Voltage Regulation	ISO	International Standards Organization	PPE	Personal Protective Equipment
BBM	Break-Before-Make (Bypass Switch)	ITIC	Information Technology Industry Council	PUE	Power Usage Effectiveness
BDM	Bypass Distribution Module	kAIC	Kiloampere Interrupting Capacity	REPO	Remote Emergency Power Off
BTU	British Thermal Unit	kVA	Kilovolt ampere	RFI	Radio Frequency Interference
CRAC	Computer Room Air Conditioning	LAN	Local Area Network	RM	Rackmount (also Rectifier Magazine)
CRAH	Computer Room Air Handler	LCD	Liquid Crystal Display	RMS	Root Mean Square
CSA	Canadian Standards Association	LED	Light-Emitting Diode	RoHS	Restriction of Hazardous Substances
DC	Direct Current	LV	Low Voltage	SCR	Silicon-Controlled Rectifier
DCIE	Data Center Infrastructure Efficiency	MBB	Make-Before-Break (bypass switch)	SLA	Service Level Agreement
EBC	Extended Battery Cabinet	MIB	Management Information Base	SNMP	Simple Network Management Protocol
EBM	Extended Battery Module	MOV	Metal Oxide Varistor	SPD	Surge Protection Device
EMC	Electromagnetic Compatibility	MTBF	Mean Time Between Failure	THD	Total Harmonic Distortion
EMF	Electromagnetic Force	MTTR	Mean Time To Repair	TVSS	Transient Voltage Surge Suppressor
EMI	Electromagnetic Interference	NEC	National Electrical Code	UL	Underwriters Laboratory
FCC	Federal Communications Commission	NEMA	National Electrical Manufacturers Association	UPS	Uninterruptible Power System (or Supply)
GFCI	Ground-Fault Circuit Interrupter	NIC	Network Interface Card	USB	Universal Serial Bus
GND	Ground	PDM	Power Distribution Module	V	Volt
HV	High Voltage			VA	Volt Ampere

Vac	Volts Alternating Current
Vdc	Volts Direct Current
VRLA	Valve Regulated Lead Acid
W	Watt

Eaton acronyms

ABM	Advanced Battery Management
AFC	American Football Conference
AM	Advanced Monitored (ePDU)
ARG	Amphibious Ready Group
BA	Basic (ePDU)
CSE	Customer Service Engineer
EOSL	End of Service Life
EMS	Energy Management System
ESS	Energy Saver System
ME	Metered (ePDU)
MI	Ethernet Monitored (ePDU)
NFC	National Football Conference
PDR	Power Distribution Rack
RMA	Return Material Authorization
RPM	Rack Power Module
ROO	Remote On/Off
RPO	Remote Power Off
RPP	Remote Power Panel
SEAL	Sea Air Land
SW	Switched (ePDU)
T&M	Time and Material
VMMS	Variable Module Management System

Other acronyms

CI	Converged Infrastructure	LEED	Leadership in Energy and Environmental Design	SVGA	Super Video Graphics Array
CPU	Central Processing Unit	MSP	Managed Service Platform	TCP/IP	Transmission Control Protocol/Internet Protocol
DCIM	Data Center Infrastructure Management	MTDC	Multi-Tenant Data Center	TDM	Time-division Multiplexing
DISA	Defense Information Systems Agency	M2MI	Machine-to-Machine Interface	UC	Unified Communications
DNS	Domain Name System	NAS	Network Attached Storage	URL	Uniform Resource Locator
DR	Disaster Recovery	NIC	Network Interface Card	VDI	Virtual Desktop Infrastructure
DSL	Digital Subscriber Line	NOC	Network Operations Center	VGA	Video Graphics Array
DVV or DV2	Data, Voice, Video	PABX	Private Automatic Branch Exchange	VLAN	Virtual LAN
E911	Enhanced 911	PaaS	Platform as a Service	VoIP	Voice over Internet Protocol
ELT	Emergency Locator Transmitter	PBX	Private Branch Exchange	VM	Virtual Machine
EMEA	Europe, Middle East, Africa	PC	Personal Computer	VPN	Virtual Private Network
FMC	Fixed/Mobile Convergence	PHI	Personal Health Information	WAN	Wide Area Network
FTP	File Transfer Protocol	PICNIC	Problem in chair not in computer		
GUI	Graphical User Interface	PMDC	Portable Modular Data Center		
HDD	Hard Disk Drive	POTS	Plain Old Telephone System		
HPC	High-Performance Computer	PSAP	Public Safety Answering Point		
HTML	HyperText Markup Language	PSTN	Public Switched Telephone Network		
HTTP	HyperText Transfer Protocol	P2V	Physical to Virtual		
MDF	Main Distribution Frame	RAM	Random Access Memory		
NNM	Network Node Manager	SaaS	Software as a Solution		
IaaS	Infrastructure as a Service	SAN	Storage Area Network		
IDF	Intermediate Distribution Frame	SATA	Serial Advanced Technology Attachment		
IP	Internet Protocol	SOA	Service-Oriented Architecture		
ISP	Internet Service Provider	SQL	Structured Query Language		
KVM	Keyboard, Video, Mouse	SSL	Secure Socket Layer		

**WE'VE ADDED
SOME SIZZLE HERE!**



Glossary of power terms

In the following glossary, we've attempted to capture the common terms related to UPS and power distribution products. If you look closely, you might see us trying to have a little fun!

Advanced Battery Management

A three-stage charging technique that automatically tests battery health. Provides advance notification when preventive maintenance is needed, allowing ample time to hot-swap batteries without ever having to shut down connected equipment significantly extending the life of your UPS's battery (and, quite possibly, your contract).

Alternating Current (AC)

An electric current that reverses its direction at regularly recurring intervals, as opposed to direct current, which is constant. Usually in a sine wave pattern, for optimal transmission of energy.

Ampere (A or Amp)

The unit of measure for the rate of flow of electricity, analogous to gallons per minute. $VA \times 0.7$ (power factor) = watts

Apparent Power

Applied voltage multiplied by current in an AC circuit which doesn't take the power factor into account. Unit is volt amperes (VA).

Arc

Sparking that results when undesirable current flows between two points of differing potential due to leakage through the intermediate insulation or a leakage path due to contamination. In astronomy, an arc is the part of a circle representing the apparent course of a heavenly body.

Audible Noise

A measure of the noise emanating from a device at audible frequencies.

Backup Time

The amount of time the battery in a UPS is designed to support the load.

Balanced Load

(1) AC power system using more than two wires, where the current and voltage are of equal value in each energized conductor. (2) Laundry with equal parts of light and dark clothes.

Battery String

A group of batteries connected together in a series.

Blackout

A zero-voltage condition lasting for more than two cycles. Also known as a power outage or failure.

British Thermal Unit (BTU)

Used to measure heat dissipation and is the amount of energy required to raise one pound of water one degree Fahrenheit. One pound of water at 32°F requires the transfer of 144 BTUs to freeze into solid ice.

Brown Field

An existing data center—often with limited possibilities for sustainable and energy-efficient designs.

Brownout

A steady state of low voltage, but not zero voltage. Brownouts often occur during summer months when energy use is high.

Canadian Standards Association (CSA)

An independent Canadian organization that tests for public safety, similar to the function of Underwriters Laboratories (UL) in the U.S. As far as we know, it doesn't set the rules for hockey.

Capacitor

An electronic component that can store an electrical charge on conductive plates.

Charger

(1) An electronic component in a UPS that provides regulated DC voltage to recharge batteries. (2) An inferior mascot for an inferior team in the AFC West.

Cloud Computing

(1) Internet- (cloud-) based development and use of computer technology. This new supplement, consumption and delivery model for IT services typically involves the provision of dynamically scalable, and often virtualized, resources as a service over the Internet. (2) Work done while traveling on a plane.

Common Mode Noise

An undesirable voltage that appears between the power conductors and ground.

Commercial Power

The power supplied by local utility companies which can vary drastically in quality throughout the U.S. depending on location, weather and other factors.

Communication Bay

Also known as an option slot, a UPS feature that enables the addition of various connectivity cards for Web, SNMP, Modbus or serial connectivity interface capabilities.



Eaton 9130 equipped with a communication bay.

Converter

A device that delivers DC power when energized by a DC source. It's also a section of a switching power supply that performs the actual power conversion and final rectification.

Crest Factor

Usually refers to current. It's the mathematical relationship between RMS and peak current. A normal resistive load will have a crest factor of 1.4142, which is the normal relationship between peak and RMS current. A typical PC will have a crest factor of 3. Unrelated to toothpaste.

Critical Equipment

Equipment such as computers, communications systems or electronic process controls, which must be continuously available.

Delta Connection

A circuit formed by connecting three electrical devices in series to form a closed loop; most often used in three-phase connections. If you fly Delta Airlines, this most likely takes place in Atlanta, Salt Lake City or Cincinnati.

Derating

A reduction of some operating parameters to compensate for a change in one or more other parameters. In power systems, the output power rating is generally reduced at elevated temperatures.

Direct Current (DC)

An electric current in which the flow of electrons is in one direction, such as supplied by a battery.

DC Distribution (DCD)

A module in a DC power system that distributes DC power to the loads. It also provides protection for the load cables.

DC Power System

An AC to DC power supply with integrated control and monitoring, and standby batteries designed to supply no-break DC power (usually 24V or 48V) to telecommunications and IT network equipment.

Double Conversion

A UPS design in which the primary power path consists of a rectifier and inverter. It isolates the output power from all input anomalies such as low voltage surges and frequency variations.

Downtime

The time during which a functional unit can't be used because of a fault within it or the environment.

Dry Contacts

Dry contact refers to a contact of a relay which does not make or break a current.

Efficiency

The ratio of output to input power. Generally measured at full-load and nominal line conditions. If the power efficiency of a device is 90 percent, you get back 90 watts for every 100 you put in, and the rest is mainly dissipated as heat from the filtration process. To think of it another way, this would be equivalent to a bartender pouring off about an ounce and a half of your beer before handing you the remaining 14.5 ounces!

Electrical Line Noise

Radio frequency interference (RFI), electromagnetic interference (EMI) and other voltage or frequency disturbances.

Electromagnetic Interference (EMI)

Electrical interference that can cause equipment to work improperly, EMI can be separated into conducted EMI (interference conducted through cables out of the UPS) and radiated EMI (interference conducted through the air).

Energy Saver System (ESS)

Innovative technology from Eaton that enables select UPS models to operate at 99 percent efficiency without compromising reliability—not to be confused with inferior “eco” modes.

ePDU

A power distribution unit that mounts to rack enclosures and distributes power to connected devices via a wide variety of output receptacles.

Federal Communications Commission (FCC)

A U.S. federal regulating body whose new EMI limitations are affecting the design and production of digital electronics systems and their related subassemblies.

Flooded Batteries

A form of battery where the plates are completely immersed in a liquid electrolyte.

Frequency

The number of complete cycles of AC voltage that occur during one second (Hz). In North America, electrical current is supplied mainly at 60 Hz, or 60 cycles per second.

Green Field

A new data center with many possibilities for sustainable and energy-efficient designs.

Ground

A conducting connection, whether intentional or accidental, by which an electric circuit or equipment is connected to the earth, or to some conducting body of relatively large extent that serves in its place.



Earth ground symbol

Harmonics

A sinusoidal component of an AC voltage that's multiple of the fundamental waveform frequency. Certain harmonic patterns may cause equipment problems

Harmonic Distortion

Regularly appearing distortion of the sine wave which is converted into a complex waveform at a multiple of the fundamental frequency.

Hertz (Hz)

A unit of frequency equal to one cycle per second.

High Efficiency Mode

A mode of UPS operation that cuts energy usage and operating costs.

High Voltage (HV)

In the context of UPS products, high voltage is anything $\geq 200V$: 200V, 208V, 220V, 230V, 240V, 250V, 480V and 600V.

High Voltage Spike

Rapid voltage peaks up to 6,000 volts.

Hot Swappable

The ability to change a module without taking the critical load off the UPS. Also see “user replaceable.”



The batteries on this Eaton 9130 UPS are hot swappable.

Insulated Gate Bipolar Transistor (IGBT)

A three-terminal power semiconductor device, noted for high efficiency and fast switching. It switches electric power in many modern appliances such as electric cars, trains and UPSs.

Impedance

The total opposition to alternating current flow in an electrical circuit.

Input Voltage Range

The voltage range within which a UPS operates in “normal” mode and doesn't require battery power.

Inrush Current

The maximum, instantaneous input current drawn by an electrical device when first turned on. Some electrical devices draw several times their normal full-load current when initially energized.

Inverter

UPS assembly that converts internal DC power to output AC power to run the user's equipment. When the inverter is supporting 100 percent of the load at all times, as with an online UPS, there is no break from utility to battery power.

Kilovolt Ampere (kVA)

A common measurement of equipment capacity equaling 1000 volt-amperes. An approximation of available power in an AC system that does not take the power factor into account.

Kinetic Energy

The energy an object possesses because of its motion.

Line Conditioner

A device intended to improve the quality of the power that's delivered to electrical load equipment. A line conditioner is generally designed to improve power quality (e.g., proper voltage level, noise suppression, transient impulse protection, etc.).

Line Interactive

An offline UPS topology in which the system interacts with the utility line to regulate the power to the load. Provides better protection than a standby system but isn't as fully prepared against irregularities as a full double-conversion system, making it the “Goldilocks” of UPS topologies.

Linear Load

AC electrical loads where the voltage and current waveforms are sinusoidal. The current at any time is proportional to voltage.

Load

The equipment connected to and protected by a UPS. Pretty rockin' Metallica album.

Load Segment

UPS configuration with separate receptacle groups, enabling scheduled shutdowns and maximum backup power time for critical devices.



This Eaton 9130 UPS is equipped with two load segments, each with three 5-15R

Low Voltage (LV)

In the context of UPS products, low voltage is anything <200V (100V and 120V).

Maintenance Bypass

An external wiring path to which the load can be transferred to upgrade or perform service on the UPS without powering down the load.

Make-Before-Break

Operational sequence of a switch or relay where the new connection is made prior to disconnecting the existing connection, that's also known as soft-load-transfer switching.

Modbus

A serial communications protocol that's the most commonly available means of connecting industrial electronic devices. It allows for communication between many devices connected to the same network.

Network Transient Protector

UPS feature that isolates networks, modems and cables from power threats, including surges and spikes.

Noise

(1) A disturbance that affects a signal; it can distort the information carried by it. (2) Random variations of one or more characteristics of any entity, such as voltage, current or data. (3) Loosely, any disturbance tending to interfere with normal operation of a device. (4) What parents with children deal with every day.

Nominal Output Voltage

The intended, ideal voltage of any given output.

Non-linear Load

AC electrical loads where the current is not proportional to the voltage. Non-linear loads often generate harmonics in the current waveform that lead to distortion of the voltage waveform.

Offline

Any UPS that doesn't fit the definition of online. Line-interactive and standby topologies are offline, as are minor skirmishes that take place just outside the boardroom.

Ohm

The unit of measurement for electrical resistance or opposition to current flow.

Ohm's Law

The voltage (E) is equal to the current (I) times the resistance (R). The formula is written: $E=IR$.

Online

(1) A UPS that provides power to the load from its inverter 100 percent of the time, regulating BOTH voltage and frequency, usually using double-conversion topology. (2) The most convenient way to shop, bank, get news, etc.

Orderly Shutdown

The sequenced shutdown of units comprising a computer system to prevent damage to it and subsequent corruption or loss of data.

Output Waveform (UPS)

The shape of the graph of alternating current on the output side of a UPS. The highest quality of an output waveform from a UPS is the sine wave, but, some UPSs provide step waves or modified sine waves.



Sine Wave

Parallel Operation

The ability of UPSs to be connected so the current from corresponding outputs can be combined into a single load.

Partition

A logical division of a hard disk created to have different operating systems on the same hard disk or to create the appearance of having separate hard

drives for file management, multiple users, or other purposes.

Peak Demand

The highest 15- or 30-minute demand recorded during a 12-month period.

Phase

The time relationship between current and voltage in AC circuits.

Plenum Cable

Cable that's laid in the plenum spaces of buildings to facilitate air circulation for heating and air conditioning systems. The plenum space is typically used to house computer and telephone network communication cables. Cable that runs between floors in non-plenum areas is rated as riser cable.

Plug and Play

An electrical device that doesn't require extensive setup to operate.

Power Factor (PF)

(1) The ratio of real power to apparent power. Watts divided by VA. Most power supplies used in communication and computer equipment have a power factor of 0.9.

$(PF = 0.9)$
 $VA \times PF = W$
 $W/PF = VA$

(2) Why DeNiro can get immediate seating in any restaurant he wants, and you can't.

Power Sag

Low voltage (below nominal 120 volts).

Power Surge

High voltage (above nominal 120 volts).

Pulse Width Modulation (PWM)

A circuit used in switching regulated power supplies where the switching frequency is held constant and the width of the power pulse is varied, controlling both lines and load changes with minimal dissipation.

Rackmount

Ability to mount an electrical assembly into a standardized rack. Generally stacked up to 42U and 19 inches wide — about the size of a pizza box but not as greasy.

Rack Unit (U)

A unit of height measurement in a rack enclosure. A U is equivalent to 1.75 inches.



The Eaton 5PX UPS occupies 2U of rack space and the optional extended battery module also occupies 2U.

Rail Kit

A set of metal brackets that allows the installation of a UPS or extended battery module in a 2- or 4-post rack.



Four-post rail kit



UPS in a two-post rack

Rectifier

A UPS component that converts incoming AC power to DC power for feeding the inverter and charging the battery.

Rectifier Magazine (RM)

A module in the DC power system used to connect the rectifiers in the power system.

Redundancy

The ability to connect units in parallel so if one fails the other(s) will provide continual power to the load. This mode is used in systems when power failure can't be tolerated.

Relay Communication

Communication between a UPS and a computer through the opening and closing of solid-state relays that are pre-defined to indicate UPS status.

Root Mean Square (RMS)

A modified average. Averaging a sine wave would give a zero, so to obtain meaningful values, the wave is first squared (S), then averaged over one period (M) and finally the square root taken (R). In a sine wave, the factor between RMS and peak is the square root of two. If you know what that means, you're pretty smart!

RS-232

(1) The standard for serial interfaces (serial refers to the eight bits of each character successively sent down one wire) used by most computers, modems and printers. (2) A little known droid in the Star Wars trilogy.

Simple Network Management Protocol (SNMP)

A User Datagram Protocol (UDP)-based network protocol. It's used mostly in network management systems to monitor network-attached devices for conditions that warrant administrative attention.

Sine Wave

A mathematical function that plots three qualities of an electrical signal over time: amplitude, frequency and phase. Clean, uninterrupted power is represented by a sine waves, which can also resemble ocean waves, though they're rarely perfect.

Single Phase

(1) Power system with one primary waveform. Lower-capacity distribution of power using only one portion of a power source that's three-phase, like what's supplied by most electric utilities. Used for heating and lighting, no large motors or other heavy-drain devices. (2) That part of junior high school in which you briefly but fiercely embrace an unusual hobby or interest, like lawn bowling, never to return to it.

Sliding Demand

Calculating average demand by averaging demand over several successive time intervals, advancing one interval at a time.

Split-phase UPS

A UPS with two output phases referenced to a neutral connection with a specific phase displacement between phases, which allows flexibility in load configuration while maintaining the availability of bypass. A split-phase UPS can provide 120V and 208V on the output simultaneously without the use of an external transformer. The capabilities for output are:

- Phase to neutral 100, 110, 120 or 127 Vac
- Phase to phase 200, 208, 220, 230, 240 Vac

Standby

(1) UPS type that "stands by," waiting for a power problem from the utility company and rapidly switching to UPS battery power to protect equipment against power failures, sags and surges. (2) The person you call after your hot date falls through, and the two of you go out for milkshakes in your sweatpants instead.

Static Switch

An electrical component in a UPS that turns power flow on and off on command without moving or mechanical components.

Step Load

An instantaneous change in the loading conditions presented to the output of a UPS.

Switching Frequency

The rate at which the source voltage is switched in a switching regulator or chopped in a DC-to-DC converter.

Technischer Überwachungs-Verein (TUV)

An independent non-profit organization that tests and certifies electrical equipment for public safety in the U.S. and worldwide.

The Far Side

The greatest cartoon strip ever. Created by Gary Larson.

Thermal Regulation

Monitoring the temperature of the batteries to ensure proper charging.

Three Phase

(1) Power supplied through at least three wires, each carrying power from a common generator but offset in its cycle from the other two. Used for heavy-duty applications. (2) The universal healing process after buying inferior power protection:

1. Denial
2. Anger
3. Calling Eaton

Topology (UPS)

The core technology of a UPS. Typically, a UPS is either standby, line interactive or online though other hybrid technologies have been introduced.

Total Harmonic Distortion (THD)

(1) How much the circuit voltage deviates from a perfect sine wave. When viewed on a meter, a poor voltage THD is most often manifested in a flat-topped waveform that comes from the inability of a power source to respond to the demands of highly nonlinear loads. (2) The parts of a difficult lecture that didn't quite make it into your brain, but rather united in a "blahblahblah" cacophony of scratchy-sounding jargon and esoteric corollaries.

Transfer Time

The length of time it takes a UPS to transfer to battery power. Typically measured in milliseconds (ms).

Transformer

(1) A magnetic device that converts AC voltages to AC voltages at any level. An ideal transformer is a lossless device in which no energy is stored that requires no magnetic current. (2) An alien robot that can disguise itself by transforming into everyday machinery.

Transient

(1) A temporary and brief change in a given parameter, typically associated with input voltage or output loading parameters. (2) Transient killer whale pods are generally comprised of an adult female and two or three of her offspring. Among the differences between residents and transients are that while resident orcas of both sexes stay within shouting distance of their mothers their entire lives, only first-born male transients maintain such intense fidelity to their mothers.

Unbalanced Load

(1) An AC power system using more than two wires, where the current is not equal due to an uneven loading of the phases. (2) A load that makes your washing machine go, "whump, whump, whump."

Underwriters Laboratories (UL)

An independent non-profit organization that tests for public safety in the U.S. UL recognition is required for equipment used in some applications.

Uninterruptible Power System (UPS)

(1) An electrical system designed to provide instant, transient-free backup power during power failure or fault. Some UPSs also filter and/or regulate utility power (line conditioning). (2) A Device whose sole purpose is to save your equipment, your data and your job.

User Replaceable

Capable of being replaced by an end user. Connected equipment may need to be shut down first. Also see "hot swappable."

Variable Module Management System (VMMS)

Innovative technology from Eaton that maximizes UPS efficiencies at low load levels while supplying the load with continuous double-conversion power.

Virtualization

The creation of a virtual (rather than actual) version of something, such as an operating system, server, storage device or network resource. Operating system virtualization is the use of software to allow a piece of hardware to run multiple operating system images at the same time.

Volt/Voltage (V)

Electrical pressure that pushes current through a circuit. High voltage in a computer circuit is represented by 1, while low (or zero) voltage is represented by 0.

Volt Amps (VA)

(1) The voltage applied to a given piece of equipment, multiplied by the current it draws. Not to be confused with watts, which are similar but represent the actual power drawn by the equipment, and can be somewhat lower than the VA rating. (2) Legendary Brigadier General from Planet Zap.

Watts (W)

The measure of real power. It's the rate of doing electrical work. $W \times 1.3 = VA$.

Wye Connection

A connection of three components made in such a manner that one end of each component is connected. It's generally used to connect devices to a three-phase power system.

For more information, please visit
powerquality.eaton.com